

# Engineering Specification

Job Name \_\_\_\_\_  
 Job Location \_\_\_\_\_  
 Engineer \_\_\_\_\_  
 Approval \_\_\_\_\_  
 Tag \_\_\_\_\_

Contractor \_\_\_\_\_  
 Approval \_\_\_\_\_  
 Contractor's P.O. No. \_\_\_\_\_  
 Representative \_\_\_\_\_

## WCA-411-WLA / WCA-411-WC-WLA Floor Mounted Lavatory Carrier with Concealed Arms and Waste Line Access Specification

Watts WCA-411-WLA / WCA-411-WC-WLA floor mounted concealed arm lavatory carrier with heavy gauge steel offset uprights and integral waste line access, adjustable epoxy coated cast iron arms with leveling screws and basin locking device, upper tie rod, and plated hardware. Carrier complies with requirements of ASME A112.6.1M up to a 250 lb (113 kg) static load.

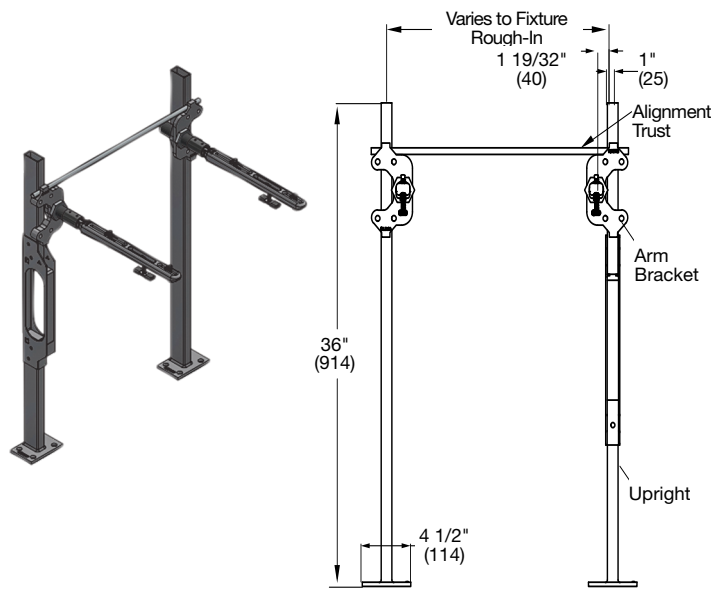

Suffix	Description
-M42	42" Long Carrier Leg
-M54	2" Chrome Plated Escutcheons
-M55	4" Chrome Plated Escutcheons

\* Specify WCA-411-WC for 27"x20" (675x500) Lavatories.

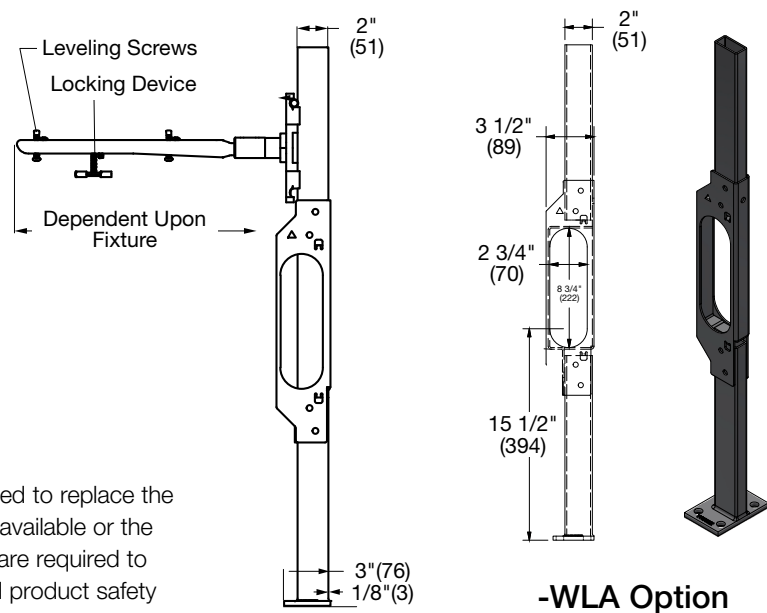

**-WLA Option**

**NOTICE**

Anchor legs to concrete floor with minimum 1/2"(13) anchor bolts (by others).

**NOTICE**

The information contained herein is not intended to replace the full product installation and safety information available or the experience of a trained product installer. You are required to thoroughly read all installation instructions and product safety information before beginning the installation of this product.

Watts product specifications in U.S. customary units and metric are approximate and are provided for reference only. For precise measurements, please contact Watts Technical Service. Watts reserves the right to change or modify product design, construction, specifications, or materials without prior notice and without incurring any obligation to make such changes and modifications on Watts products previously or subsequently sold.



**USA:** T: (800) 338-2581 • Watts.com  
**Canada:** T: (888) 208-8927 • Watts.ca  
**Latin America:** T: (52) 55-4122-0138 • Watts.com