

Job Name \_\_\_\_\_

Contractor \_\_\_\_\_

Job Location \_\_\_\_\_

Approval \_\_\_\_\_

Engineer \_\_\_\_\_

Contractor's P.O. No. \_\_\_\_\_

Approval \_\_\_\_\_

Representative \_\_\_\_\_

# Series 800

## Detector Check for Automatic Fire Sprinkler Systems

Size: 4" - 10" (100mm - 250mm)

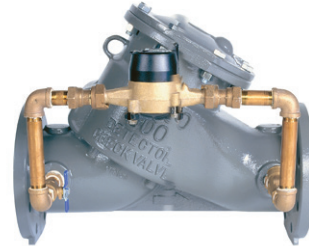

800  
with Optional  
Bypass

The FEBCO Series 800 is used in the protection of potable water supplies from unauthorized water usage. This requires installation of the proper valving to measure water loss. The Series 800 Detector check is not a backflow prevention assembly and should not be used as such.

### Features

- UL listed and FM approved for horizontal or vertical installation.
- Spring-loaded swing check for reliability and minimum head loss.
- 250psi (17.2 bar) working pressure for superior strength.
- DuraCast ductile iron body for superior strength and lighter weight.
- Fully rubber encapsulated ductile iron disc for strength.
- Fusion epoxy coated, inside and out, for corrosion protection.
- Simple service procedures.
- Cast lifting ring for ease of installation.
- 4", 6", 8", and 10" Sizes
- ¾" standard bypass; optional 1" size
- End Connections – Flanged ANSI B16.42, Class 150

### Operation

In a non-flow condition, the mainline check and bypass check are closed and the meter is idle. All flows up to approximately 10 gpm will flow through the standard ¾" (20mm) bypass. This operation at low flow rates is accomplished by designing the differential pressure drop across the bypass line to be slightly less than the mainline check valve. Therefore, the mainline check valve remains closed so that low flows through the fireline system are registered by the bypass meter.

Flows in excess of approximately 10 gpm will open the mainline check valve causing flow to occur through the mainline assembly and the bypass line.

### Approvals

4", 6", 8" and 10"



### Specifications

Detector check shall consist of a single spring-loaded swing check in parallel with a bypass meter assembly. Seat rings shall be bronze, bolted to the valve bodies with an elastomer seal.

The main check assembly shall be hinge guided. Head loss through the assembly shall not exceed 3psi (21 kPa) at velocities from zero up to and including 15fps (4.6mps).

Mainline check body and cover shall be manufactured of Ductile Iron ASTM A536 Grade 6545-12. Ductile iron bodies shall be flanged ANSI B16.42, class 150 and fusion epoxy coated 8 mills minimum to meet A.W.W.A. C550-90. Detector check shall be rated at 250psi (17.2 bar) working pressure and be UL listed and FM approved for both horizontal and vertical installation. Disc shall be rubber encapsulated ductile iron.

Detector check shall meet or exceed requirements of Underwriters Laboratory and Factory Mutual Research Corporation. Detector check shall be FEBCO Series 800 or prior approved equal.

### Pressure – Temperature

Maximum working pressure: 250psi (17.2 bar)  
Hydrostatic test pressure: 500psi (34.5 bar)  
Temperature range: 32°F to 110°F (0°C to 60°C)

### Materials

Main valve body:	Ductile iron Grade 65-45-12 Fusion Epoxy coated Internal and External AWWA C550-90
Trim:	Bronze
Elastomers:	Nitrile
Spring:	Stainless Steel
Bypass meter:	Totalizing type GPM/CFM
Size:	5/8" x 3/4"

### ⚠ WARNING

It is illegal to use this product in any plumbing system providing water for human consumption, such as drinking or dishwashing, in the United States. Before installing standard material product, consult your local water authority, building and plumbing codes.



A WATTS Brand

## Capacity

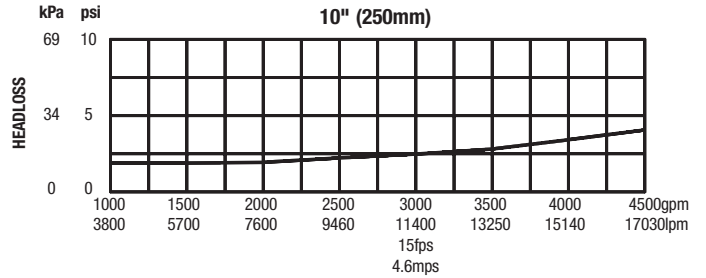
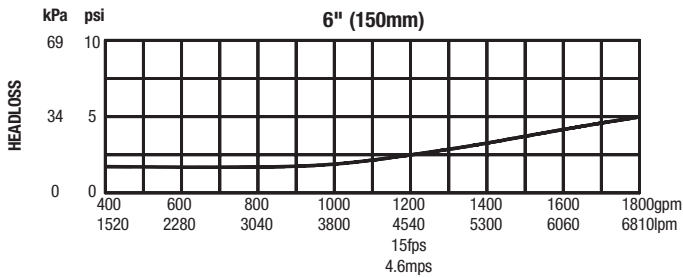
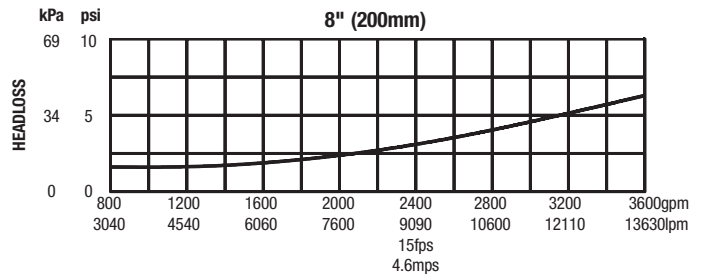
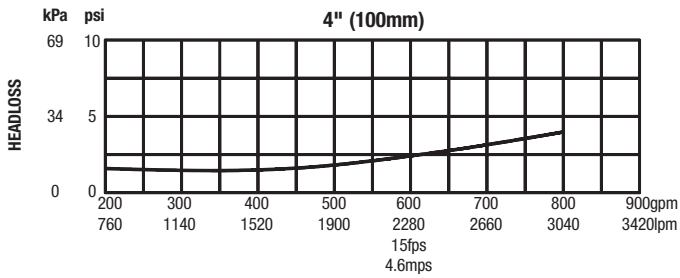

### NOTICE

The information contained herein is not intended to replace the full product installation and safety information available or the experience of a trained product installer. You are required to thoroughly read all installation instructions and product safety information before beginning the installation of this product.

## Dimensions – Weights

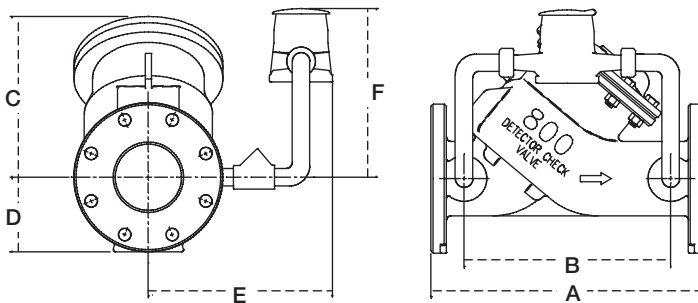

U.S. Patent No. 4,989,635

### BYPASS SIZES

STANDARD		OPTIONAL	
in.	mm	in.	mm
4	100	3/4	20
6	150	1"	25
8	200		
10	250		

### Size: 4" - 10" (100 - 250mm)

SIZE (DN)		DIMENSIONS										WEIGHT			
		A		B		C		D		E		F		lbs.	kgs.
in.	mm	in.	mm	in.	mm	in.	mm	in.	mm	in.	mm	in.	mm		
4	100	16½	419	12½	318	9¾	248	4½	114	10½	267	11	279	76	34.5
6	150	22½	572	17	432	13¾	346	5½	140	11¾	295	11	279	157	71.2
8	200	26½	673	21	533	16¾	425	6¾	171	12⅝	321	11	279	215	97.5
10	250	36¾	921	28	711	20	508	8	203	13¾	349	11	279	370	167.8

Dimensions shown are nominal, allowance must be made for normal manufacturing tolerances.



A WATTS Brand

USA: Tel: (800) 767-1234 • Fax: (800) 788-4491 • FEBCOonline.com  
 Canada: Tel: (905) 332-4090 • Fax: (905) 332-7068 • FEBCOonline.ca  
 Latin America: (52) 81-1001-8600 • FEBCOonline.com