

Maintenance Manual

RadiantPEX®

RadiantPEX+™

RadiantPERT™

RadiantPEX-AL™



Table of contents

<i>RadiantPEX Properties</i>	2
<i>RadiantPERT Properties</i>	3
<i>RadiantPEX-AL Properties</i>	4
<i>Cautions</i>	4
<i>Design Overview</i>	5
<i>Manifold Placement</i>	6
<i>Connections</i>	7
<i>Instructions for Installing ASTM F1960 Expansion fittings for Watts PERT Tubing</i>	8
<i>UnderFloor</i>	11
<i>Walls & Ceilings</i>	16
<i>Slabs</i>	17
<i>Thin-slabs</i>	22
<i>Snow melt</i>	26
<i>Glycol</i>	33
<i>Manifolds</i>	34
<i>Supply & Return Piping</i>	36
<i>Pressure Drop Charts</i>	38

Welcome to the exciting world of radiant floor heating. This manual contains information related to radiant floor installations. For design information, please consult RadiantWorks® Professional design software.

This manual illustrates Watts poly-based tubings, RadiantPEX®, RadiantPEX+™ (cross-linked polyethylene), RadiantPERT™ (Polyethylene Raised Temperature), and RadiantPEX-AL™ (PEX-Aluminum-PEX). Although many of the installation steps are similar, important differences will be noted.

RadiantPEX and RadiantPEX+ may be referenced throughout this manual as simply PEX, or PEX tubing. RadiantPEX-AL may be referenced as PAP, or PAP tubing. RadiantPERT may be referenced throughout this manual as simply PERT tubing. If the topic pertains to all four product types, the term “tubing” may be used. Specific product names will only be used if special or specific installation details exist for that application or condition.

Many of the accessory items used with RadiantPEX, RadiantPEX+, RadiantPERT and RadiantPEX-AL tubing are mentioned in this manual. New tools and accessory items are added to the Watts product offering on a regular basis. Please refer to the Watts product catalog for current product information. Additional product information may also be found at our web site www.wattsradiant.com.

Watts offers a wide range of support options, from local wholesalers and representatives to our factory-direct toll-free number.

When you select Watts, you select an entire support team.

⚠ WARNING



Read this Manual BEFORE using this equipment. Failure to read and follow all safety and use information can result in death, serious personal injury, property damage, or damage to the equipment. Keep this Manual for future reference.
THIS UNIT SHOULD BE INSTALLED ONLY BY QUALIFIED PERSONNEL!

NOTICE

This manual only covers installation of Watts RadiantPERT, RadiantPEX, RadiantPEX+, and RadiantPEX-AL and should not be used for the installation of our flexible Onix radiant tube or R-flex insulated tubing. This is not a design manual. For design assistance, we encourage you to contact us or our representatives for a design analysis using RadiantWorks® Professional system design software.

Before designing or installing a radiant heating or snow melting system, you should always consult with local, experienced design and installation professionals to ensure compliance with local building practices, climate conditions, state and local building codes, and past customs.

⚠ CALIFORNIA PROPOSITION 65 WARNING

Warning: This product contains chemicals known to the State of California to cause cancer and birth defects or other reproductive harm. (California law requires this warning to be given to customers in the State of California). For more information: www.watts.com/prop65.

RadiantPEX and RadiantPEX+ Properties

RadiantPEX and RadiantPEX+ are a cross-linked polyethylene tubing used for radiant floor heating and snow melting applications. Both are manufactured with an integral ethylene vinyl alcohol (EVOH) DIN Standard O₂ barrier that limits oxygen diffusion through the walls of the tubing to less than 0.10g/m³/day at 40°C (104°F) water temperature. RadiantPEX+ offers an additional polyethylene outer layer for superior protection against abuse and reduced noise transmission.

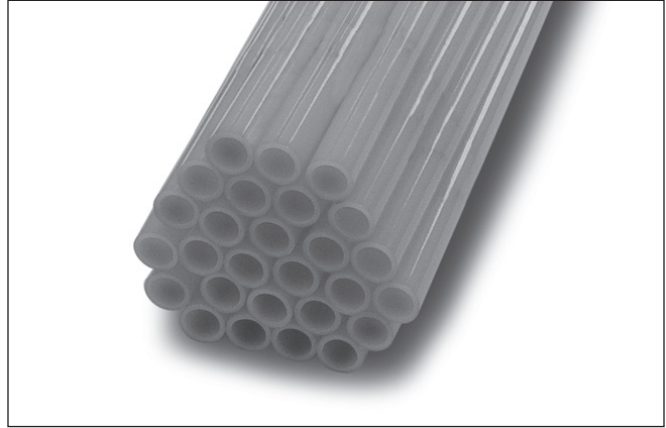

RadiantPEX and RadiantPEX+ Standards and Listings

- RadiantPEX and RadiantPEX+ are manufactured to American Standard Testing Methods (ASTM F876 and F877) and to SDR9 dimensions. These standards include requirements and testing methods for materials, workmanship, dimensions, environmental stress cracking, sustained hydrostatic pressure strength, bend strength, and degree of cross-linking. RadiantPEX and RadiantPEX+ meet or exceed these standards.
- RadiantPEX and RadiantPEX+ are tested and listed by the NSF International to NSF-14 (rfh) and NSF P171 (chlorine resistance).
- RadiantPEX and RadiantPEX+ are tested and listed by Intertek to ASTM E84 (Standard Test Method for Surface Burning Characteristics of Building Materials) and meet the requirements of NFPA 90A.
- RadiantPEX and RadiantPEX+ are tested and listed to UL263 (Fire Tests of Building Construction and Materials) by Intertek.
- RadiantPEX and RadiantPEX+ are listed by the International Code Council Evaluation Service (ICC) to Report #ESR-1155, and PMG-1008 which give compliance to IPC, IMC, UMC, and UPC.
- All RadiantPEX and RadiantPEX+ pipe is certified to CSA Standard B137.5.

NOTICE

Expansion Rate: 1.1"/100'/10°F.
Allow 1/8" slack for every foot of installed tubing.

Description	ID (OD)	Minimum Bend Radius	Fluid Capacity gal/100'	Min. Support Vertical Distance	Min. Support Horizontal Distance
3/8" RadiantPEX+	0.360" (1/2")	4"	0.50	48"	32"
1/2" RadiantPEX+	0.485" (5/8")	5"	0.92	48"	32"
5/8" RadiantPEX+	0.584" (3/4")	6"	1.34	48"	32"
3/4" RadiantPEX+	0.681" (7/8")	7"	1.84	60"	32"
1" RadiantPEX+	0.875" (1-1/8")	9"	3.04	60"	32"
1-1/4" RadiantPEX	1.069" (1-3/8")	11"	4.53	60"	32"
1-1/2" RadiantPEX	1.263" (1-5/8")	13"	6.32	60"	32"
2" RadiantPEX	1.653" (2-1/8")	17"	11.15	60"	32"

Temperature	Pressure
73.4°F (23°C)	160 psi (1.10 MPa)
180°F (82.2°C)	100 psi (0.69 MPa)
200°F (93.3°C)	80 psi (0.55 MPa)

NOTICE

The bend radius for RadiantPEX+ may require some bends to be "light bulb" in shape. This method allows for tighter on center spacing without compromising the tubing.

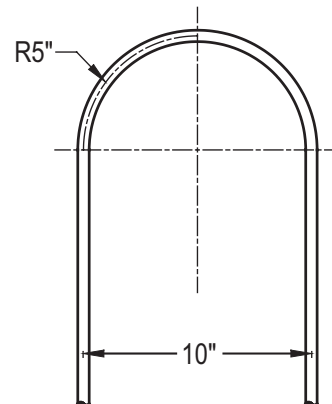
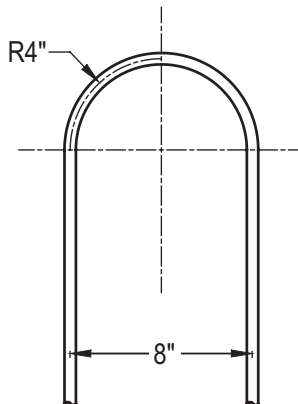
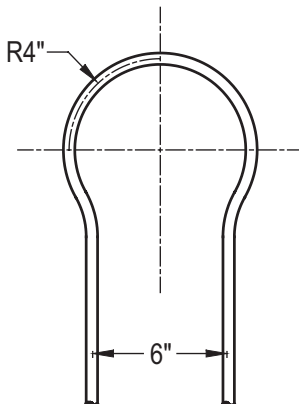

RadiantPERT Properties

WattsPERT is a 5-layer PE-RT (polyethylene raised temperature) tubing used for radiant heating, cooling, snow melting, and distribution piping. RadiantPERT is manufactured with an integral ethylene vinyl alcohol (EVOH) DIN Standard O2 barrier that limits oxygen diffusion through the walls of the tubing to less than 0.10g/m³/day at 104°F (40°C) water temperature. 5 layer RadiantPERT offers a protective PE-RT layer to the EVOH.



RadiantPERT Standards and Listings

- RadiantPERT is certified to ASTM F2623 for Polyethylene of Raised Temperature (PE-RT) SDR 9 Tubing by NSF and CSA. This standard includes requirements and testing methods for materials, workmanship, dimensions, sustained hydrostatic pressure strength, and bend strength. RadiantPERT meets or exceeds these standards.
- RadiantPERT is tested and listed to NSF-14 (rfh).
- Maximum operating temperature and pressure:
 - 160 psi at 73°F
 - 80 psi at 180°F
- PPI TR-4 listing at 73°F and 180°F
- RadiantPERT is certified to the Uniform Mechanical Code by NSF.

Expansion Rate: 1.1"/100'/10°F.

Description	Nominal I.D. (in.)	Min. Bend Radius (in)	Fluid Capacity (Gal/100')	Min. Support Vertical Distance	Min. Support Horizontal Distance
3/8" (9.5 mm) RadiantPERT	0.35" (8.89 mm)	2.5" (63.5 mm)	0.53 (2.4 l)	48"	32"
1/2" (12.7 mm) RadiantPERT	0.475" (12.06 mm)	3.125" (79.37 mm)	0.96 (4.4 l)	48"	32"
5/8" (15.9 mm) RadiantPERT	0.574" (14.57 mm)	3.75" (95.25 mm)	1.39 (6.3 l)	48"	32"
3/4" (19.1 mm) RadiantPERT	0.671" (17.04 mm)	4.375" (111.12 mm)	1.89 (8.6 l)	60"	32"
1" (25.4 mm) RadiantPERT	0.863" (21.92 mm)	5.625" (142.87 mm)	3.12 (14.2 l)	60"	32"

Max. Temperature	Max. Pressure
180°F (82.2°C)	80 psi (5.5 bar)
73.4°F (22.7°C)	160 psi (11.0 bar)

NOTICE

The bend radius for RadiantPERT may require some bends to be "light bulb" in shape. This method allows for tighter on center spacing without compromising the tubing.

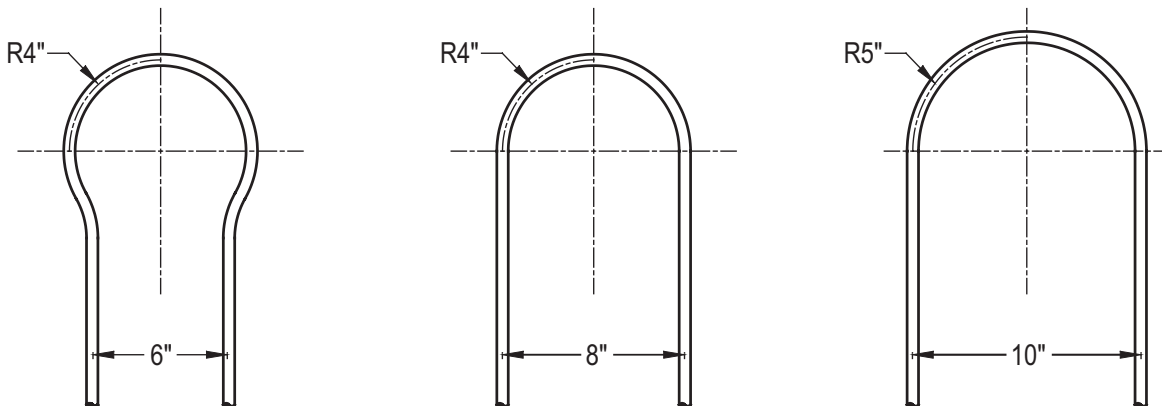

RadiantPEX-AL Properties

RadiantPEX-AL is a multi-layered, cross-linked polyethylene tubing with an aluminum inner core for radiant floor heating and snow melting applications. RadiantPEX-AL is manufactured with an integral aluminum oxygen layer that limits oxygen diffusion through the walls of the tubing to less than 0.006g/m³/day at 40°C (104°F) water temperature.

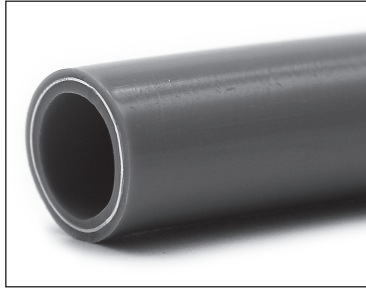

RadiantPEX-AL Codes & Listings

- Manufactured to ASTM F-1281-05
- Tested and listed by the National Sanitation foundation (NSF-pw – Standards 14 and 61 and NSF-rfh).
- Carries the UPC certification mark, as approved by the International Association of Plumbing and Mechanical Officials (IAPMO).

Expansion Rate: 0.156"/100'/10°F.

Note: No special considerations required to account for thermal expansion.

NOTICE

1. RadiantWorks® Professional designs, which include heat loss as well as material calculations, should be performed prior to installing a radiant system.
2. There are several manifold options to choose from, including stainless steel and copper tubular. Each manifold should be sized in accordance to the system requirements and the fitting system required.
3. RadiantPEX and RadiantPERT fittings are not interchangeable with RadiantPEX-AL fittings. Fittings correspond to the tubing options used.

Description	ID (OD)	Minimum Bend Radius	Fluid Capacity gal/100'	Min. Support Vertical Distance	Min. Support Horizontal Distance
3/8" RadiantPEX-AL	0.346" (0.472")	2.5"	0.53	48"	32"
1/2" RadiantPEX-AL	0.500" (0.630")	3.2"	0.91	48"	32"
5/8" RadiantPEX-AL	0.637" (0.787")	4.0"	1.62	48"	32"
3/4" RadiantPEX-AL	0.806" (0.984")	5.5"	2.53	60"	32"
1" RadiantPEX-AL	1.032" (1.260")	6.5"	3.95	60"	32"

Temperature	Pressure
73.4°F (23°C)	200 psi (1.38 MPa)
180°F (82.2°C)	125 psi (0.86 MPa)
200°F (93.3°C)	100 psi (0.69 MPa)

NOTICE

Even though the bend radius for RadiantPEX-AL is slightly tighter than RadiantPEX+, it may still require some bends to be "light bulb" in shape. It is important, however, to ensure the minimum bend radius is not exceeded, as this will cause the tubing to kink. This method allows for tighter on center spacing without compromising the tubing.

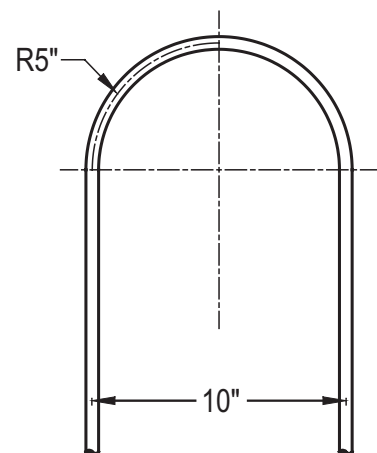
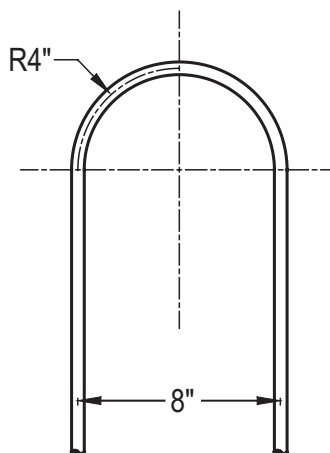
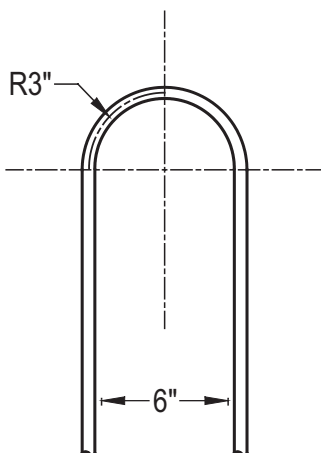

CAUTIONS

General Handling & Storage

1. If PEX or PERT connections must be made in temperatures lower than 30°F, caution must be taken to allow the tubing to form a proper seal against the barb. Apply the connection slowly to ensure the PEX or PERT material conforms to the barb.
2. Do not allow the fluid temperature to exceed:
 - 200°F at 80 psi for RadiantPEX and RadiantPEX+.
 - 200°F at 100 psi for RadiantPEX-AL.
 - 180°F at 80° psi for RadiantPERT.
3. Do not allow the tubing to be exposed to sunlight, or direct UV exposure for more than 30 days maximum. If stored outside, tubing must remain covered by a UV resistant material.
4. Do not allow the tubing to come in contact with any of the following:
 - Petroleum based products
 - Pipe sealants
 - Firewall sealants, except those rated for use with PEX or Polyethylene
 - Kerosene
 - Gasoline
 - Fuel oils
 - Cutting oils
 - Asphalt
 - Contaminated soils or building materials.
5. Do not use if the tubing has visible gouges, cuts, cracks, abrasions, signs of physical damage, or other defects.
6. Do not use in swimming pools or other systems that use high levels of chlorine.
7. Use bend supports when necessary (excluding RadiantPEX-AL).
8. Do not kink. If kinking occurs, use a repair coupling.
9. Do not expose tubing to rough terrain that may cause punctures, cuts, or other damage.
10. Do not use tubing to transfer natural gas or any other unapproved substance.

General Installation Cautions

1. Do not install within 6" horizontally or 12" vertically to a heat source such as:
 - recessed light fixtures
 - combustible flue vents
 - general heating appliances
2. Do not install directly to a heat source. A metallic adapter, minimum 18" in length, must be used between the heat source and tubing.
3. Do not support fixtures directly from the tubing, such as hose bibs or shut-off valves.
4. Protect the tubing via sleeves where it transitions through a concrete slab, concrete wall, or other framing material.
5. Not to be used with Onix or R-flex products.

Design

For all radiant projects, both large and small, a system design should be performed. This design should include at minimum, a radiant heat loss calculation, minimum tubing requirements, and pump size calculations.

RadiantWorks® Professional (RadPRO) software should be used to design for all building specifications and all system components. A copy of RadPRO can be obtained through your local Watts representative.

Manifolds

Each zone will generally have one manifold pair - a supply and a return. Watts offers a wide range of manifolds including custom tubular and stainless steel manifolds. More information on manifold options can be found in the Watts product catalog.

With respect to any design, the manifold location has a direct impact not only on the aesthetics of a room, but also on the tubing being installed.

1. Manifolds should be placed in a location that allow them to remain accessible, but also out of sight. Cabinets, behind doors, and in closets are good locations. These locations allow for the use of a cover plate or manifold box over the manifold to keep the assembly hidden from everyday view.
2. Manifold placement determines the minimum tubing circuit length. The minimum circuit length is the distance from the manifold to the farthest point, taking right angles, and back. For most residential projects, 200 ft. circuits are adequate. For most commercial projects, 300 - 400 ft. circuits are used.
3. Locate the manifold within the given zone. If a manifold is located outside the zone boundary, then twice the distance (supply and return) to the manifold needs to be added to each circuit length.

For example, if a zone calls for 180 ft. circuits, and the manifold is moved to a location 10 ft. away, then 20 ft. is added to the circuit. The circuit lengths required for this zone will be 200 ft.

4. Manifolds should be mounted horizontally, if possible. This allows for easier circuit connection to the manifold. Also, if a vent/purge assembly (recommended) is installed on the manifold pair, then the manifold pair must be mounted horizontally in order to allow the vents to work properly without leaking.
5. Manifold sizes are based on the zone flow rates (g.p.m.). The smallest trunk size provided by Watts is 1". For commercial and snow melt applications larger manifolds, 1-1/4" to 6" i.d., are available.

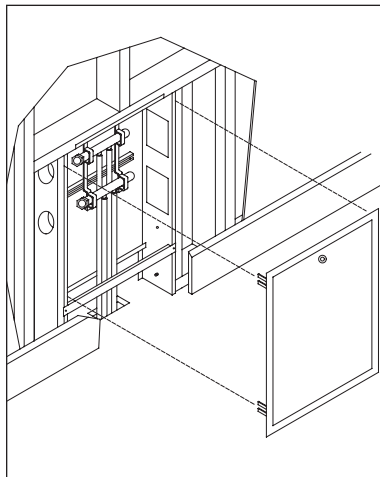
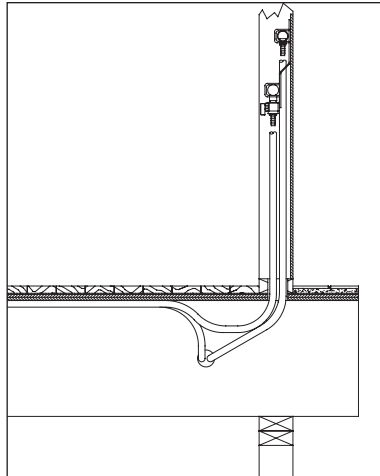

NOTICE

1. Manifold placement can sometimes be key to how well the radiant tubing is installed. Placement dictates whether the calculated tubing lengths are long enough to cover the given area. Too far outside the given heated zone and the circuits may be too short.
2. A key element to manifold placement is accessibility. Manifolds must remain accessible well after the installation is complete. This is due to possible future maintenance needs.
3. When deciding on a manifold location choose a location that is hidden yet accessible, such as within closets. The more accessible the manifold is, the easier maintenance tasks will be. A few good locations include:
 - Bedroom closets
 - Vanities (if certain the vanity will not move)
 - Under cabinets (if certain cabinet will not move)
 - Utility and linen closets
4. A final tip for selecting a manifold location is to choose an area so the manifold can be installed in a horizontal position. This position is critical for the vent/purge assembly to function properly. Any other position, such as the manifolds on their side or upside down, may lead to unwanted leaks.

Connections

There are four connection options when using RadiantPERT, three options when using RadiantPEX+, and two options when using RadiantPEX-AL.

RadiantPEX+ / RadiantPERT

Connections discussed in this section apply to 3/8" - 1" RadiantPEX+ and RadiantPERT tubing. Please see the Supply and Return Piping section for connection options for larger diameter RadiantPEX tubing.

CrimpRing

An annealed copper band that is compressed around the RadiantPEX+ or RadiantPERT and barb using a Crimp tool.

Install Steps

1. Cut a clean, square end to the tube.
2. Slide the CrimpRing over the tubing.
3. Slide the tubing over the fitting. Make sure the tubing is flush against the base of the fitting.
4. Slide the CrimpRing up so that it is positioned in the middle of the fitting. Allow about 1/8" of tubing between the CrimpRing and the base of the fitting.
5. Use a crimp tool to complete the connection.
6. Use a Go-No Go gauge to verify the connection.
7. See specific tool instruction sheet for maintenance information.



CrimpRings

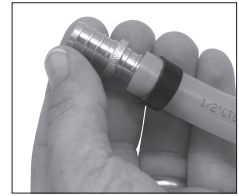

CrimpMaster crimp tool



CrimpAll tool kit

CinchClamp

A stainless steel band that is "cinched" against the RadiantPEX+ or RadiantPERT and the fitting. CinchClamps use a Cinch tool. This is the same fitting that is used for CrimpRing connections.

CinchClamps



One Handed CinchTool

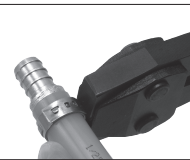

CinchTool

Install Steps

1. Cut a clean, square end to the tube.
2. Slide the CinchClamp over the tubing.
3. Slide the tubing over the fitting. Make sure the tubing is flush against the base of the fitting.
4. Slide the CinchClamp up so that it is positioned in the middle of the fitting. Allow about 1/8" of tubing between the CinchClamp and the base of the fitting.
5. Use a cinch tool to complete the connection by placing the tab on the CinchClamp in the jaw of the cinch tool and squeeze. The two-handed tool will release automatically when the connection is completed. The one-handed ratcheting CinchTool should be manually released when the white dot is fully visible in the indicator.

SS T20 Compression

SST20 Compression fittings use a ring to compress the RadiantPEX+ or RadiantPERT against the fitting. A standard open-end wrench is used for this connection. Compression fittings for RadiantPEX+/RadiantPERT are not interchangeable with compression fittings for RadiantPEX-AL.

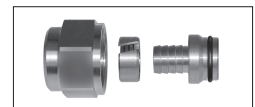

SST20 compression fitting

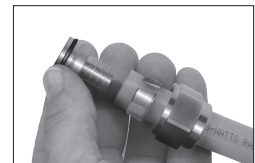

Install Steps

1. Cut a clean, square end to the tube.
2. Slide the compression nut over the tubing.
3. Slide the compression ring over the tubing.
4. Slide the tubing over the fitting. Make sure the tubing is flush against the base of the fitting.

Connections

5. Place the base of the fitting into the compression base located on the manifold.
6. Slide the compression nut up and begin threading it onto the base. The compression ring will automatically be positioned over the fitting.
7. Use an open-end wrench to complete the connection. Tighten the connection until snug and then an additional 1/4 turn.

RadiantPERT

ASTM F1960

American Society for Testing and Materials (ASTM) Standard Specification for Cold-Expansion Fittings With PEX Reinforcing Rings for use with Watts RadiantPERT Tubing.

- F1960 compression rings are PEX.
- Compression is made by placing a compression ring onto tube, expanding PERT tube and ring, inserting a full-flow fitting, and holding in place until tube/ring memory secures the connection.
- Fittings are reusable if barb is undamaged.
- F1960 Expansion Fittings are designed only for Watt's PE-RT tubing and is not suitable for RadiantPEX or RadiantPEX+ tubing.

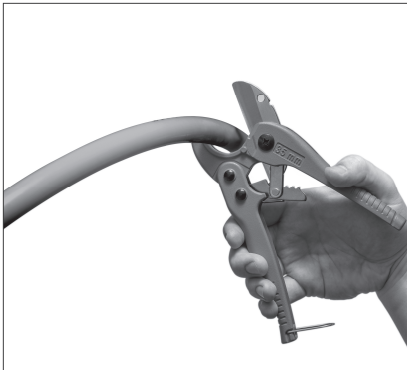

1. Cut tube at 90-degrees. Do not crush OD of tubing with cutters.

Hint: Slightly rotate cutter during blade engagement.



2. Install PEX ring onto OD of RadiantPERT tubing.



3. Using an ASTM F1960 tube expander, expand sleeve fully. Repeat expansions, rotating expander 1/8-turn between expansions. Note: To limit the amount of time for tube compression onto fitting in cold environments, expand the tube/sleeve slowly and only enough to fully insert the fitting. Keeping sleeves warm will speed retraction and inhibit unequal expansion. Use Milwaukee Tools M12 or M18 Cordless ProPex® Expansion Tool for expanding tubing. Milwaukee tools are sold through Milwaukee distributors.

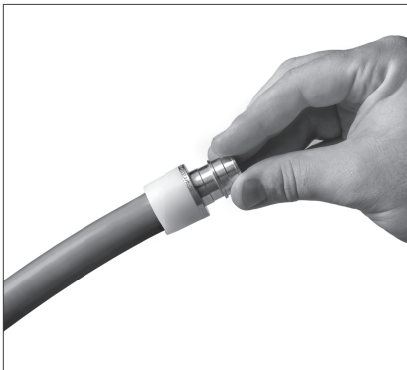

4. Insert fitting into expanded tube and sleeve. Assure proper expansion so that fitting is touching tube and sleeve. Hold fitting in place until tube/sleeve memory constrict annularly around the fitting.



5. The installation is complete with a visibly secure connection. Remove defective connections. Test completed joint.

⚠ CAUTION

F1960 Application Cautions

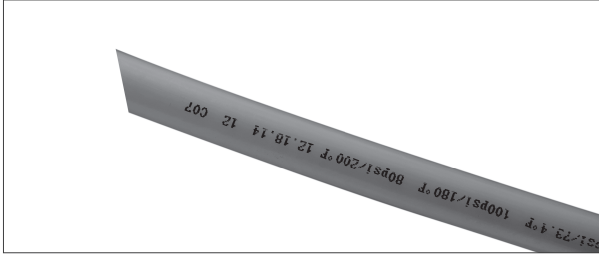

Tube not cut squarely – ring and tube need to be mated perfectly and installed fully over F1960 barb for a viable seal.

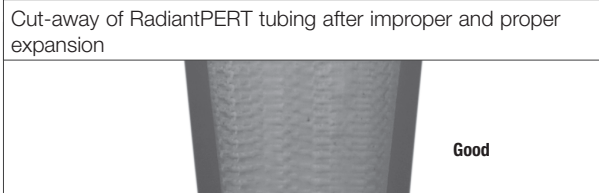

Leak path. Expansion did not rotate between multiple expansions, leaving a groove or leak path past the fitting barb. Expansion made with a defective expansion head.



Ring must be kept around 55°F or greater to assure expansion is uniform. Remove any expanded ring that displays unequal expansion.

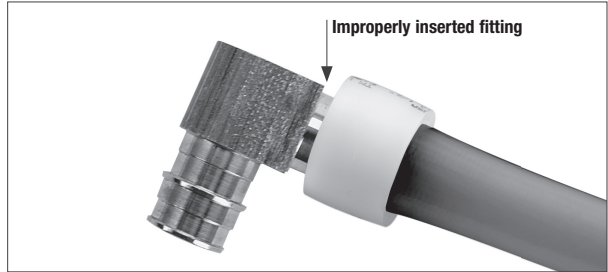

Fitting not inserted completely into expanded tube and ring. Ring not fully covering PERT tubing.



Damaged, cut or grooved sealing barb.

Connections

RadiantPEX-AL

All RadiantPEX-AL fittings and connections must use the Reamer tool to properly shape the tubing to accept the fitting. To use the Reamer Tool, push the tubing onto the appropriately sized tip and rotate. A small bevel tool will shave a portion of the inner layer, allowing the tubing to slide easily past the o-rings and for a better fit against the base of the fitting.

Press

Press fittings use a special fitting with O-rings on the fitting and an encapsulating stainless steel sleeve. A Press tool is used to compress the RadiantPEX-AL against the fitting. When making the Press fitting, make sure the RadiantPEX-AL is seated properly in the fitting. Viewing holes are provided at the base of the fitting to ensure the RadiantPEX-AL is in the proper position. If the RadiantPEX-AL is not seen in the viewing window, do not complete the connection.

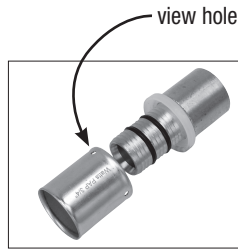

Press fitting

Install Steps

1. Cut a clean, square end to the tube.
2. Use the Reamer tool to shape and prep the tubing.
3. Make sure the insulator base is in place at the base of the fitting.
4. Make sure the Press sleeve is seated against the insulator base of the connection.
5. Slide the RadiantPEX-AL tubing onto the fitting until the tubing is visible in the view port.
6. Place the Press fitting into one side of the jaws.
7. Close the jaws firmly. Tool will stop automatically when complete.

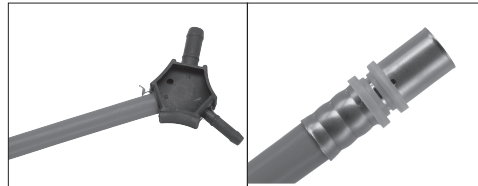

Reamer tool

completed press connection



PressAll Tool kit

NOTICE

Remove O-rings and insulator base before soldering sweat fittings.

Compression

Compression fittings are specially designed for use with RadiantPEX-AL tubing. Although similar to the SST20 connections, the RadiantPEX-AL Compression fittings are designed specifically for the Radiant PEX-AL tubing and can not be used for RadiantPEX+ or RadiantPERT.

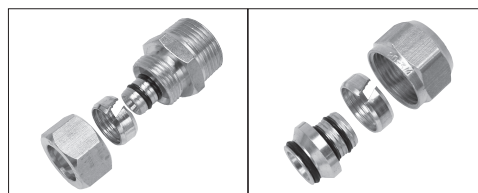

RadiantPEX-AL T20
Compression Fitting

SST20 Compression Fitting

NOTICE

1. Do not cross-match tubing and fitting styles. CinchClamps and CrimpRing connections can not be used with RadiantPEX-AL. Likewise, Press connections cannot be used with RadiantPEX+ or RadiantPERT.
2. When choosing Compression fittings, make sure the compression fitting chosen is for the correct pipe option. RadiantPEX+ / RadiantPERT SST20 fittings will be chrome plated, RadiantPEX-AL fittings are all brass, and have two o-rings that help seal the inside surface of the tube.
3. Only RadiantPEX-AL needs to use a Reamer tool.
4. For more detailed information on all fitting and connection options, refer to the corresponding specification sheets.
5. Reamer tools are available in one of two styles: 3-side and T-handle.

UnderFloor

Install Steps

1. Cut a clean, square end to the tube.
2. Use the Reamer tool to shape and prep the tubing.
3. Slide the compression nut over the tubing.
4. Slide the compression ring over the tubing.
5. Make sure the insulator washer insert is in place at the base of the fitting.
6. Slide the tubing over the fitting. Make sure the tubing is seated against the insulator washer insert.
7. Slide the compression nut up and begin threading it onto the base. The compression ring will automatically be positioned over the fitting.
8. Use an open-end wrench to complete the connection (**do not use a crescent wrench**). Tighten the connection until snug and then an additional 1/4 turn.

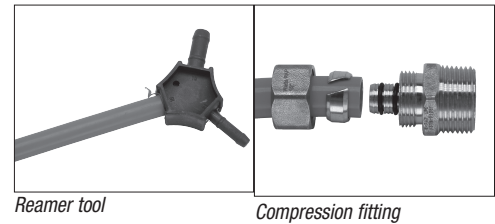

UnderFloor Application

Frame floor projects minimize the structural load requirements often associated with light weight concrete (thin slab) construction, a plus for new construction or renovation projects.

Even though some installation details may vary from application to application, basic design considerations remain the same. The most important goal is to make sure the tubing is installed in accordance with the design parameters. If not, the system may not function as desired.



Insulation Requirements

1. Tight Seal

One of the largest areas of heat loss with any underfloor application is convective loss through the band joists and other perimeter areas. It is important to have a tight seal between the horizontal insulation and the joist itself. The tighter the joist cavity, the better the system will perform.

2. Foil Face

The foil on the insulation will ensure most of the heat and energy coming from the tubing is reflected upward towards the subfloor where it is evenly distributed.

3. Air Gap

A 2-4" air gap is necessary between the tubing and the insulation. This air gap helps increase the effective R-value of the insulation while fully optimizing the ability of the foil to reflect energy. The main goal is to keep the tubing from coming into contact with the insulation. If contact is made, energy is no longer reflected upwards, but rather, is conducted downward. This can reduce the effective heating of the floor by 10-20%, depending on the load conditions and thickness of insulation.

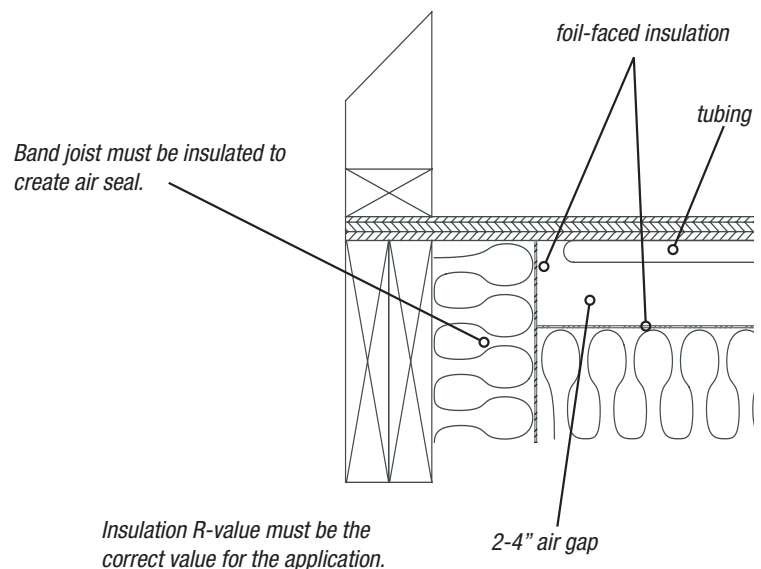

UnderFloor

4. R-Value

As a rule of thumb, an R-Value of at least 4 times higher than the floor is desired. For most indoor conditions, an R-13, or a 3½" batt should be used. When installing over an unheated area, exposed area or crawlspace, a minimum R-19 or 6" batt should be used.

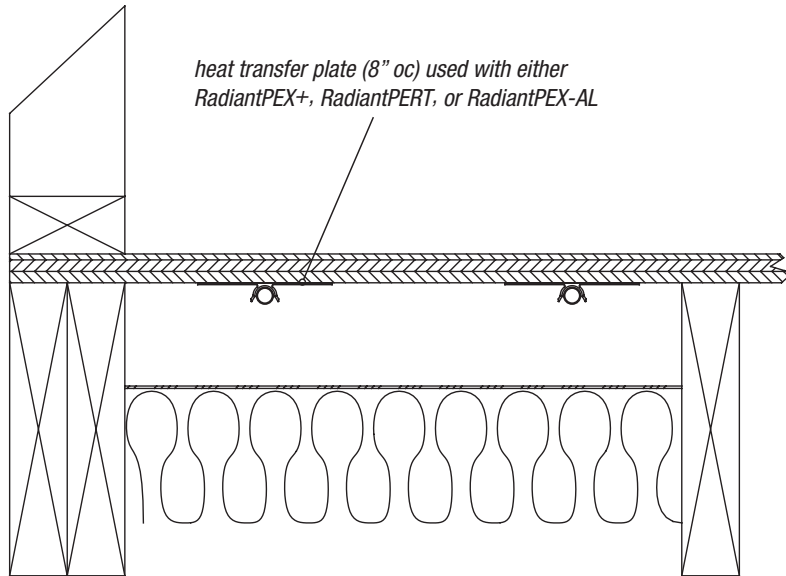

Spacing

Tubing is generally installed 8 inches on center, to the underside of the subfloor for an UnderFloor application.

NOTICE

Do not install tubing wider than 8" on center.

Closer spacing may be used (depending on attachment method) in areas of high heat loss, such as an exposed wall with a high percentage of glass or areas with a low thermal conductivity, such as areas with thicker than normal subfloor or dense carpet and pad.

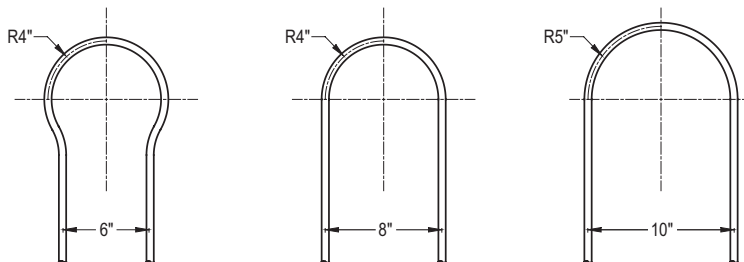

bend radius for RadiantPEX+ and RadiantPERT tubing

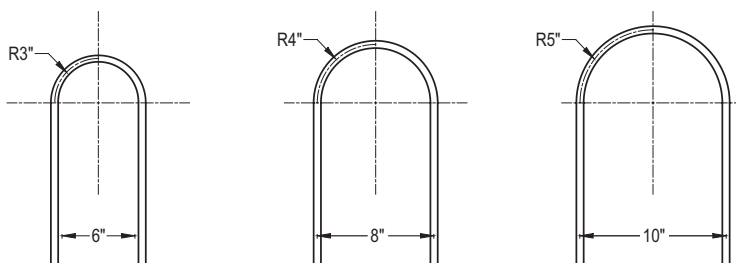

bend radius for RadiantPEX-AL tubing

NOTICE

1. When installing any RadiantPEX+, RadiantPERT, or RadiantPEX-AL application, it is important to follow those steps associated with a particular tubing type. In some cases attachment methods are not universal, such as with a Staple-Up approach. This method can only be used with RadiantPEX-AL.
2. Tube spacing, fluid temperatures, required pipe diameter, and circuit length are functions of the radiant design. It is recommended to always have a radiant design performed before installing any radiant system.
3. Bend supports are generally needed for RadiantPEX+ and RadiantPERT tubing when trying to make a tight bend or if added support is needed to transfer the tubing through a wall or other barrier.
4. RadiantPEX-AL does not require bend supports due to the nature of the tubing. It is important, however, to not over bend RadiantPEX-AL as kinking will occur.

UnderFloor

NOTICE

Tighter than 8" oc tube spacing is only possible if 3/8" tubing is used. If 1/2" or larger tubing is used on the project, the design should maintain a constant 8" oc spacing.

Installation Methods

When considering a RadiantPEX+ or RadiantPERT UnderFloor application, it is important to first determine the style of underfloor system being used. There are three main methods of installing an UnderFloor system: staple up (RadiantPEX-AL Only), with heat transfer plates and suspended.

Pulling the tubing through the floor joist is the same for all methods described. The only difference between the various methods is the attachment device used to secure the tubing to the subfloor.

Do not install clips wider than 32" on center for RadiantPEX+ or RadiantPERT and no wider than 60" on center for RadiantPEX-AL.

Fastener Methods

Tubing can be attached to the subfloor in a variety of ways. Each of the following can be used, depending on installation requirements.

1. Aluminum Heat Transfer Plates

Heat transfer plates are aluminum plates that are either rolled or extruded and come in various lengths. Watts offers a rolled aluminum plate designed to be used with 1/2" tubing. Extruded aluminum heat transfer plates come in 4 ft. lengths and are installed 8" on center with a 2-4" gap between plates. Extruded plates can be used with either 3/8" or 1/2" tubing .

2. FlexPlate™

FlexPlate is light weight, flexible, and easily cut. Use for 1/2" RadiantPEX+ or RadiantPERT. Beginning on the loop-end of the circuit, approximately 12" away from the band joists or other blocking, place a FlexPlate heat transfer plate over the RadiantPEX+, securing the plate with a 1" crown staple. Continue installing the plates end-to-end for the entire joist bay attaching two plates, side by side, leaving the tubing installed 8" on center.

3. Suspended

LockDowns are installed 18-32" apart, depending on layout shape and required support, with 8" on center spacing. RadiantPEX+, RadiantPERT , or RadiantPEX-AL tubing is locked into the clip.

NOTICE

Note: Suspended systems provide no contact with the subfloor or joists and generally operate at a reduced BTU capacity requiring high supply water temperatures.

4. Staple Up (RadiantPEX-AL Only)

Tubing is stapled directly to the subfloor every 12-18" on center. For areas that are hard to reach with the staple gun, NailTites may be used to secure the RadiantPEX-AL to the subfloor. When stapling tubing, make sure to use a compressor set to 100 psi for proper penetration into the subfloor. Due to various subfloor materials, it may be necessary to reduce or increase the compressor pressure. Staples should not depress or kink the RadiantPEX-AL tubing.

Bend Supports

When using RadiantPEX+ or RadiantPERT tubing, bend supports may be required if it is necessary to maintain a certain bend radius, or if connecting to a fitting immediately after a bend.

RadiantPEX-AL piping does not require bend supports as the pipe itself will maintain whatever bend is created. Bends can be made with a traditional pipe bender or by a spring bender if the bend is near the end of the tubing. For smaller size pipe (3/8" and 1/2") bends can be made by hand if care is taken not to over bend the tubing.

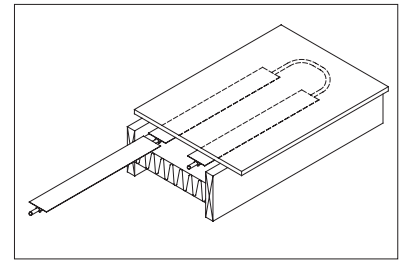

extruded plates place 8" oc with 2-4" gap, used with any tubing

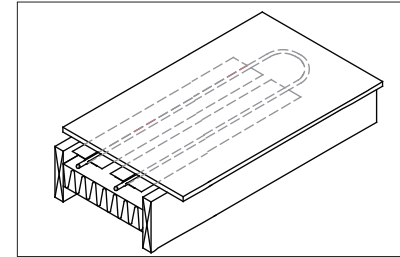

for Flexplate, use standard 1" crown staples , 4 across at 12" intervals along the length of the plate. Do not staple tubing.

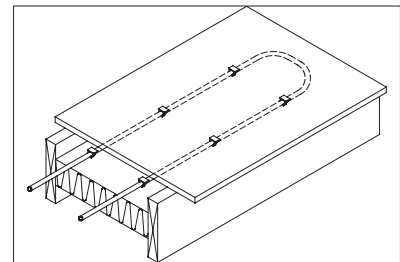

suspended installation using LockDowns™ spaced 32" max (RadiantPEX+, RadiantPERT) or 60" max (RadiantPEX-AL)

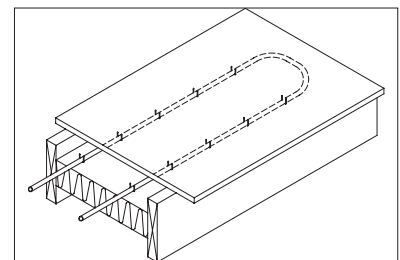

Staple-up applications (Radiant PEX-AL only) use standard 1-1/4" staples spaced every 12-18".



Bend supports are available in two styles: Mid-Run and terminal. Both are used with RadiantPEX+ or RadiantPERT tubing.



Spring benders are used with RadiantPEX-AL tubing to prevent over bending and kinking of the tubing. Spring benders are not needed for RadiantPEX+ or RadiantPERT.

Pulling Tubing

It is important to install the fasteners (LockDowns or Heat Transfer Plates) before beginning to pull the tubing. If using Heat Transfer Plates, make sure the end of the plate is de-burred after cutting the plate to fit before installing the tubing.

Measure the distance from the manifold to the farthest point moving in right angles to ensure proper circuit length is being used. This distance should be less than the circuit length for the zone.

Install Steps

1. Determine manifold location and install manifolds.
2. Determine Zone Boundaries
Before tubing is installed, visually inspect the area to determine the zone boundaries. This helps determine where the first circuit is to be placed, while identifying any obstacles that may be in the way.
3. Confirm Tubing Requirements
Measure the distance from the manifolds to the farthest point in the zone. Make sure the minimum circuit length is at least twice this distance. If not, the tubing will not be long enough to reach the farthest point of the zone and return (see slab section for illustration).

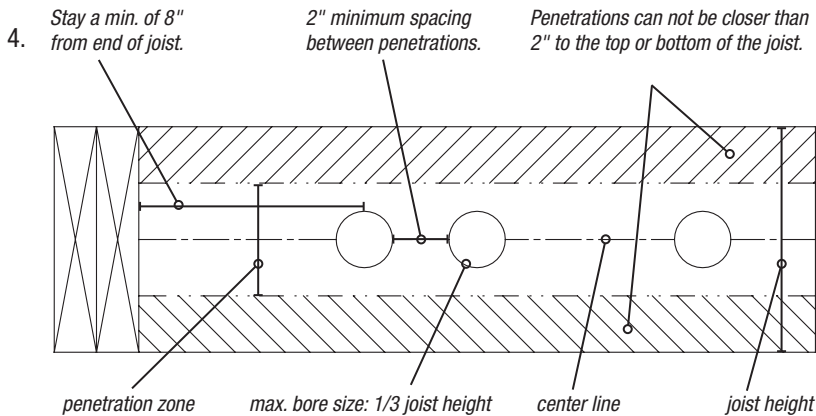

When crossing a joist at a perpendicular angle, it is recommended to follow BOCA 2305.3.2 guidelines for allowable joist penetrations.

Drill joists (if necessary)

Drill in accordance to structural requirements (see diagram for typical). To help keep the holes in line, it may be helpful to first mark the joists with a chalk line. Drill a 1-1/2" hole for 1/2" tubing.

5. Place tubing on unwinder.
6. Pull one end of the tubing from the Unwinder and feed through the first joist.
7. Create a large loop with the tube and feed the free end through the adjacent joist.
8. Make a small loop in each bay as you work towards the bay farthest from the manifold.

NOTICE

1. There are multiple ways to pull tubing through a joist system. The method(s) discussed in this manual are only a sample of those used by installers. These techniques are the most proven with the best results. If another technique is selected, it is important to follow all tubing requirements, such as minimum bend radius.

UnderFloor

9. Pull enough tubing to fill the last bay.
If additional tubing is required pull it from the loop in the previous bay. If too much was pulled, push it back into the previous bay. Care should be taken not to kink the tubing.

10. Run the end of the tubing back to the manifold.
This may be done using the original joist hole (if using RadiantPEX-AL) or by drilling a return hole 8" away from the first (if using RadiantPEX+ or RadiantPERT). Using a dedicated return path will help reduce noise sometimes associated with RadiantPEX+ or RadiantPERT underfloor application.

11. Place the tubing into the fasteners.
Begin by attaching the run of tubing that is part of the return line going back to the manifold. This side of the loop is "fixed". The other side is free to feed from the unwinder and previous bays in case extra tubing is required.
- Do not run the tubing all the way to the band joist. Keep the tubing approximately 8-12" from the end of the joist to accommodate insulation.

- It is always better to work from the farthest bay back towards the manifold location. For details on a SmartTrac floor installation, refer to the SmartTrac installation manual.

12. Always remember to place the tubing so bends have the largest radius possible.

13. Inspection

After all the circuits are installed, take a few minutes to walk each circuit and visually inspect the tubing for possible damage caused during installation. If damage is found, repair it using an approved Watts repair kit.

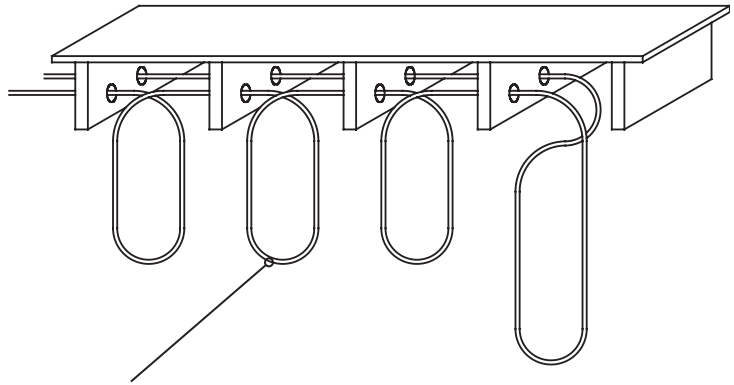

Drop loops help reduce the potential for kinks to occur as well as provide for the maximum bend radius for easier installation.

Feed enough tubing to complete the last bay. If more tubing is required, pull from the loop in the previous bay. If too much is present, push the excess back through to the previous bay.

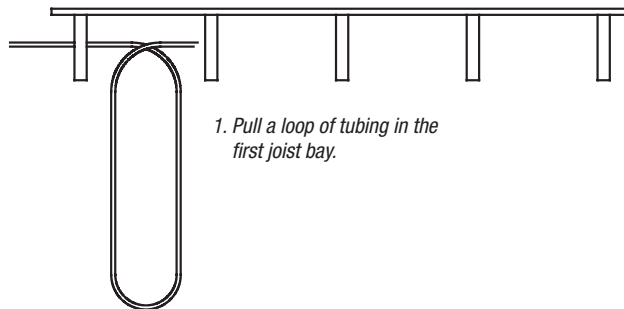

1. Pull a loop of tubing in the first joist bay.

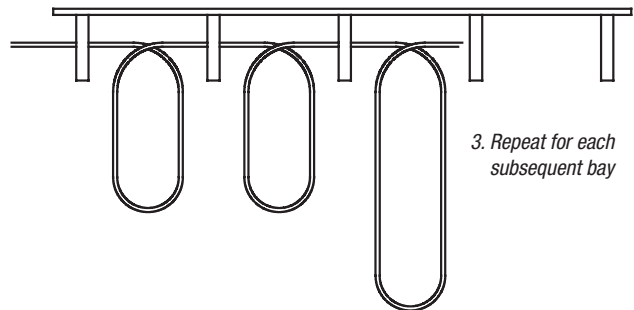

3. Repeat for each subsequent bay

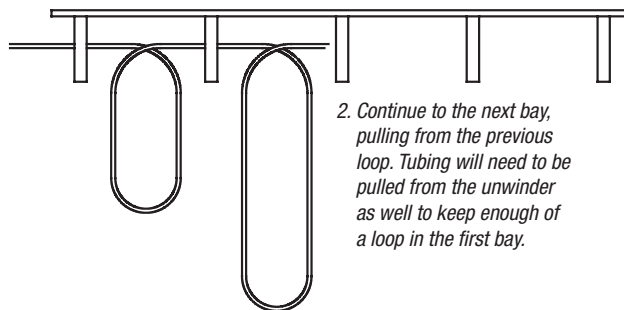

2. Continue to the next bay, pulling from the previous loop. Tubing will need to be pulled from the unwinder as well to keep enough of a loop in the first bay.

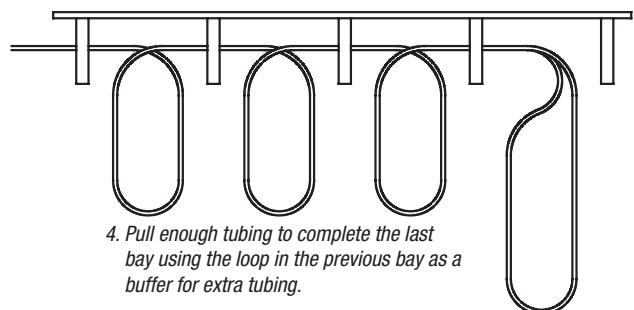

4. Pull enough tubing to complete the last bay using the loop in the previous bay as a buffer for extra tubing.

UnderFloor

14. Pressure Test

Pressure test the system with 50-100 psi water or air for 24 hours. Do not use water if exterior temperatures are near or below freezing 32°F (0°C) conditions.

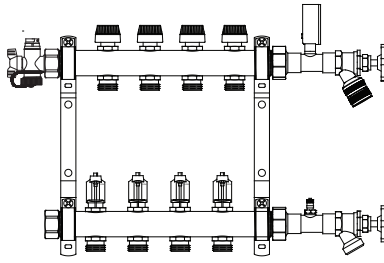

When possible, pressure test with water to 50-100 psi. If water is not present, or if freezing is a concern, air may be used. Minor pressure fluctuations (10-15 psi) are expected and are due to atmospheric temperature changes as well as potential mass thermal changes (slab curing).

NOTICE

1. Wall and ceiling applications are a great choice when auxiliary heat is needed, or if the construction profile prevents access to the floor.
2. Since drywall is typically the finished “covering”, it is important to keep the supply fluid temperature below 120°F (49°C). Higher temperatures may cause damage to the drywall. Because of this, it is usually necessary to have different supply conditions (mix valves, circulators, etc) to deliver the proper fluid temperature.
3. When installing a radiant wall, it is recommended to go no higher than 4' up from the floor. This is to help prevent any unnecessary damage occurring from wall hangings such as pictures or shelves.

Wall and Ceiling Applications

Walls and ceilings are installed in a similar fashion as underfloor applications, only in reverse, causing the radiant panel to be facing down, or out, instead of up.

It is good practice to limit the height of the radiant wall to 4 ft. off the floor. This is because pictures and other wall hangings are installed above this height.

CAUTION: Do not allow the supply fluid temperature of a radiant wall or ceiling to exceed 120°F (49°C) as damage to drywall material may result.

When possible, do not install tubing in an outside exposed wall as a possible increase in heat loss may occur.

Installation Method 1 (Any Tubing)

1. Install foil-faced insulation with the foil facing the heated space.
2. Install extruded heat transfer plates to the studs or joists.

NOTICE

to use the extruded plate in this fashion the tubing track is facing in, towards the insulation. The tube snaps in place from behind.

3. Install the Tubing.
 - It may be necessary to drill a transfer hole at the base or top of the stud to allow the tube to transfer from bay to bay.

System fluid temperature should not exceed 120°F (49°C) degrees due to gypsum wall board temperature limitations.

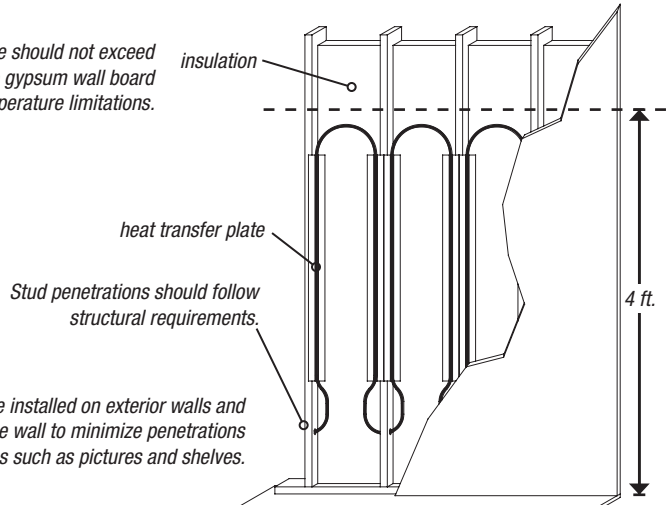

Wall systems should not be installed on exterior walls and should not exceed 4 ft up the wall to minimize penetrations from wall hangings such as pictures and shelves.

Walls and Ceilings

Installation Method 2 (Any Tubing)

1. Install foil-faced insulation with the foil facing the heated space.
2. Install a layer of 1/2" plywood on top of the studs or joists.
3. Install SmartTrac on top of the plywood in the same fashion as described in the SmartTrac installation manual. If installing a radiant wall, run the Header Sticks vertically along the sides of the wall. It may be necessary to use more Grippers than what would normally be used for a SmartTrac floor application, especially when installing a radiant ceiling.

Install Method 3 (Any Tubing)

1. Install foil-faced insulation with the foil facing outward, or downward, towards the room.
2. Install 3/4" sleepers perpendicular to studs, 1-1/4" apart.
3. Install rolled heat transfer plates between sleepers.
4. Install tubing in plate.

NOTICE

When using rolled plates, it is sometimes beneficial to place a bead of silicone in the channel prior to installing the tubing.

Installation Method 4 (RadiantPEX-AL Only)

1. Install foil-faced insulation with the foil facing the heated space.
2. Lay poultry netting (chicken wire) across the studs. Allow enough slack in the netting to push the tubing flush, but in contact, with the drywall.
3. Attach the RadiantPEX-AL to the netting with the use of cable ties.
4. Lay the drywall over the RadiantPEX-AL.

Inspection and pressure testing for wall and ceiling applications are the same as described in the UnderFloor section.

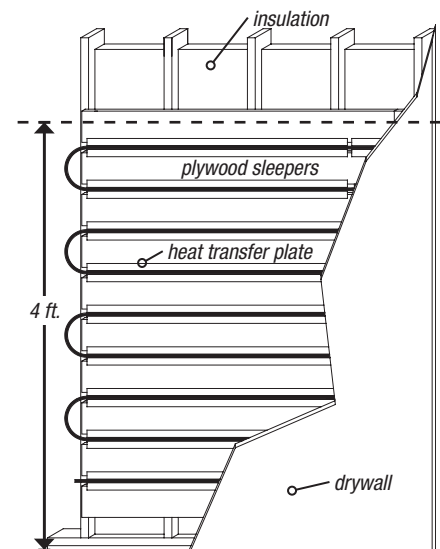
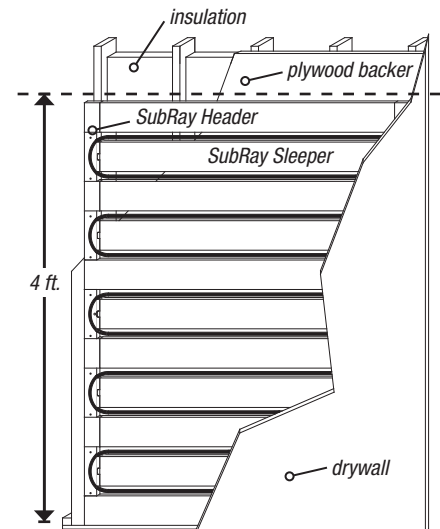

Slab Application

Slab applications are one of the most common applications used in commercial, as well as some residential, radiant heating systems.

Since the slab is generally in direct contact with the ground, energy can be rapidly lost to the surroundings. To help reduce these back and edge losses, certain conditions must be met prior to the radiant installation to help ensure proper system operation.

Site Preparation

A radiant slab should be placed on well drained base rock material.

Sub-surface water will rob heat from a radiant slab faster than a boiler can produce it. Basements and slabs installed in hillsides should have good drainage to carry any subsurface groundwater away from the site. The slab should be placed above an ample amount of crushed rock or gravel.

Radiant slabs placed on low-lying, poorly drained soil or sand should have at least one inch (minimum of R-5) of extruded polystyrene (Dow® Blue Board®) or equivalent insulation under the entire slab—even in southern climates.

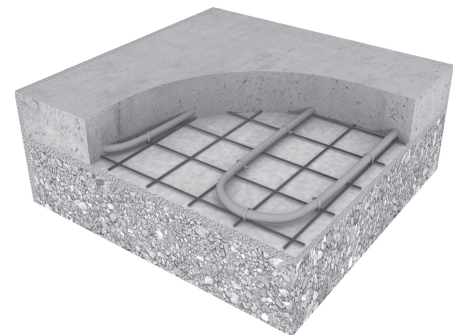

Slab

A radiant slab should never be placed directly on top of clay or organic subsoil, as these materials can conduct heat away from the radiant slab, and the soils may shrink in volume when directly exposed to the heat of the slab. An intervening layer of four or more inches of crushed rock or river gravel should be used.

A radiant slab should never be placed directly on top of solid bedrock, as this material can rapidly conduct heat from the slab into the earth. Crushed rock and insulation must be installed between the slab and rock.

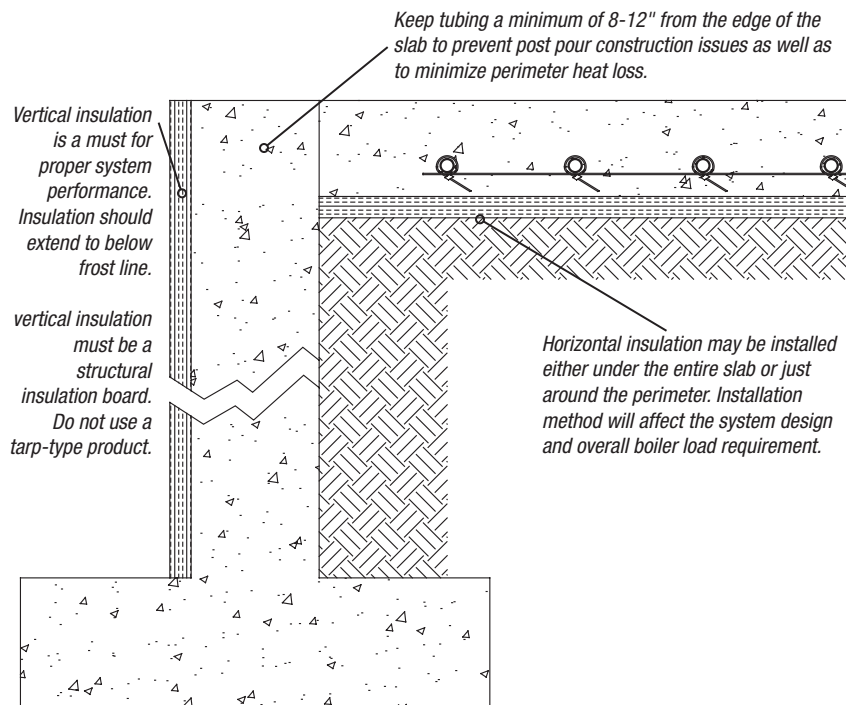

In some cases, one to two inches of sand may be placed on top of the coarser base rock material. This gives a smooth, level surface to lay down rigid insulation, and helps prevent possible damage to the rigid insulation in high traffic areas prior to concrete placement. The sand layer also allows for more precise leveling to minimize any variation in the slab thickness.

NOTICE

Check with local building codes to see if they allow the use of sand directly underneath slabs.

Insulation Requirements

Unlike a frame application where the insulation is installed after the radiant tubing, a slab application requires the insulation to be installed first, making the insulation part of the structure.

In a slab on grade application there are two main areas to insulate: vertically around the perimeter of the slab and horizontally underneath the slab. Both will aid in the slab's response and efficiency. Of these two, the vertical edge insulation is the most important because it prevents heat loss directly to the outside environment. Horizontal insulation helps decrease the slabs required start up time by isolating the heating mass from the ground mass below.

Typically the system will see a reduction of about 10-20% in overall operational efficiency if horizontal insulation is not used.

NOTICE

1. Some of the key elements of a residential slab application are the following:
2. Vertical edge insulation is a must (depth requirement is to go below frost line).
3. Horizontal insulation will increase the system performance and response time.
4. A minimum of 2" of slab coverage is necessary above the tubing to accommodate most slab requirements, as well as post pour conditions (frame walls, cut joints, etc.).
5. Commercial slabs follow the same guidelines with the exception of horizontal insulation. Most commercial slabs will use horizontal insulation around the edge of the slab and not under the entire slab. This is due in part to structural loading conditions and cost. Be sure to consult with the structural engineer before deciding on horizontal insulation.
6. Any post pour penetrations must be monitored closely, especially in the case of a saw cut where water is present during the cutting operation.

Slab

Type of Insulation

Extruded polystyrene insulation board is recommended mainly because the insulation board will be in direct contact with the soil. Extruded polystyrene insulation will not degrade over time due to excess moisture or soil acidity. "Beaded" insulation boards should not be used because they are not strong enough and will break down over time. This, in turn, will cause structural instability.

In most applications, 1" insulation board is recommended. A thicker board may be used if the slab is to be installed in a cold, aggressive climate. Always check with an architect or structural engineer to ensure the appropriate insulation is used.

Foil-faced insulation is not required or recommended when insulating a radiant slab. Foil-faced insulation is used when an air gap is able to be maintained. In the case of a slab application the tubing is completely encapsulated in the concrete, eliminating any air gap.

Watts does not recommend Bubble-type insulation under a slab application until more research has been done and performance has been verified. Care should be taken with all insulation types to confirm the actual R-value. Many blanket or tarp style insulations have R-values in the range of 1-1.5.

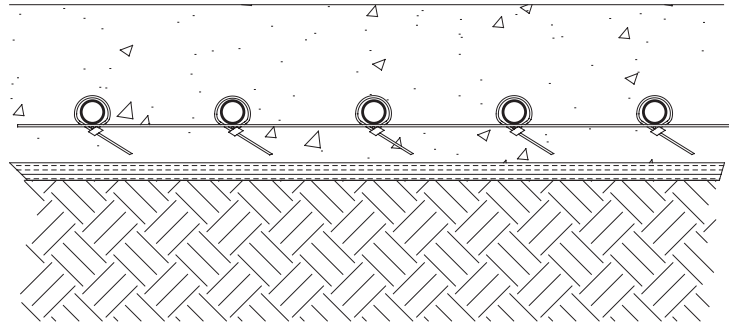

Horizontal insulation can be either a structural insulation board or a tarp-type product. Make sure insulation is compatible with structural requirements such as loading.

Special Construction Considerations

Slab applications are generally the easiest to install. However, it is important to remember what type of construction steps remain after the concrete slab has been poured. In most projects, the concrete is the first phase of the project. Interior walls and other support structures still have to be installed, most being mounted or secured directly to the slab. With this in mind, it is important to take some preliminary steps to help protect the tubing during construction.

Control Joints

Concrete slabs will expand and contract due to thermal changes. To prevent damage to the slab, expansion joints are used to control this movement. In some cases cut joints are used to control where cracking is to occur. Make sure the tubing is protected according to the requirements of the control joint.

Spacing

Residential slabs will use 6", 9", or 12" tube spacing with some perimeter banding. Spacing wider than 12" may produce unacceptable floor temperature variations (striping).

Commercial slabs may use anywhere from 6"-24" spacing depending on the use of the area.

Fasteners

Tubing can be attached to either the rewire, rebar or below slab insulation. Each of the following can be used, depending on installation requirements.

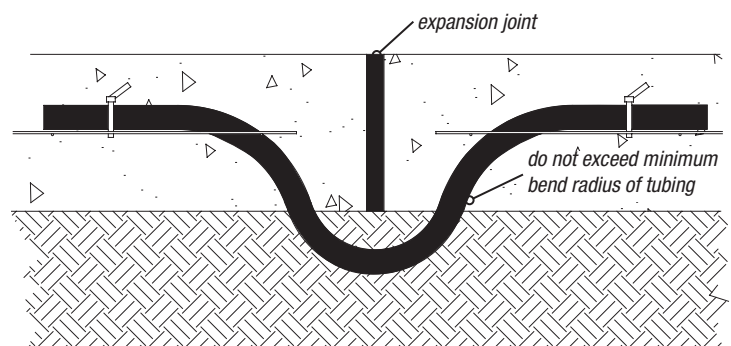
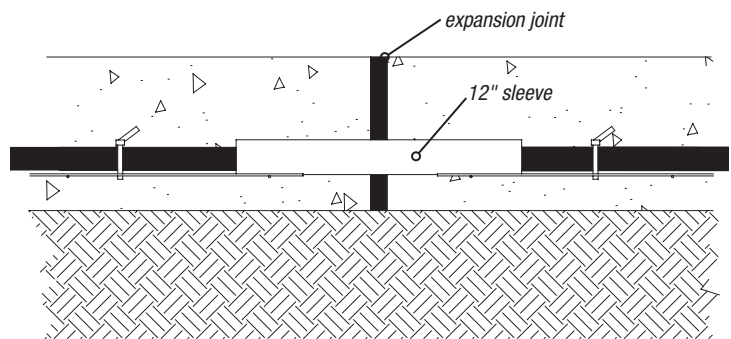

Expansion joints can be installed in several ways, depending on slab construction requirements. If a sleeved approach is to be used, make sure the sleeve extends at least 6" to either side of the joint. Rigid PVC or a similar material should be used as the sleeve.

Slab

1. CableTies—nylon cable tie used to secure all sizes of tubing to either rewire or rebar 12"-18" on center.
2. ScrewClips—used to secure 3/8" or 1/2" tubing to foamboard insulation 18"-24" on center.
3. Foamboard Staples—used to secure 3/8" or 1/2" tubing to either foamboard or tarp insulation 18"-24" on center.
4. RailWays—used to secure 3/8", 1/2", or 5/8" tubing to various substrates. RailWays must be secured every 4 ft on center prior to the tubing being installed.

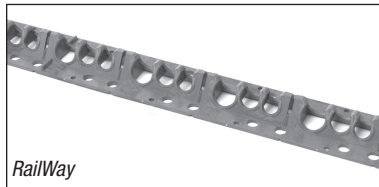
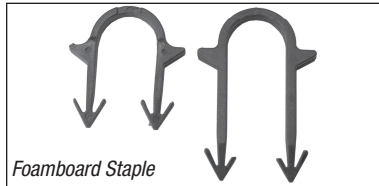
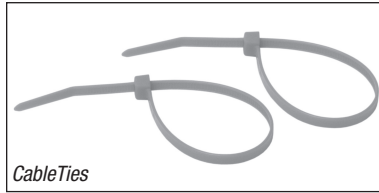

Perimeter Banding

Banding refers to any area where the tubing is installed with a tighter on center spacing. Usually seen along exterior walls with higher than normal heat loss.

Slab Profile and General Details

In slab-on-grade applications, it is important to maintain at least 2-3" of concrete covering above the tubing. More coverage may be necessary depending on the structural requirements of the slab.

Install Steps

Manifold locations, final concrete thickness and zoning details are just a few items that can affect how a concrete application is installed. The following guidelines cover the most common installation conditions. If a given situation is not covered here or if unexpected circumstances arise, please contact Watts or a Watts Representative.

NOTICE

1. Fastener options should be chosen based on slab construction details.
2. When deciding on a manifold location, make sure the circuit lengths used can reach the farthest point and back via right angles. Verify tubing lengths before moving a manifold location from the initial design location.

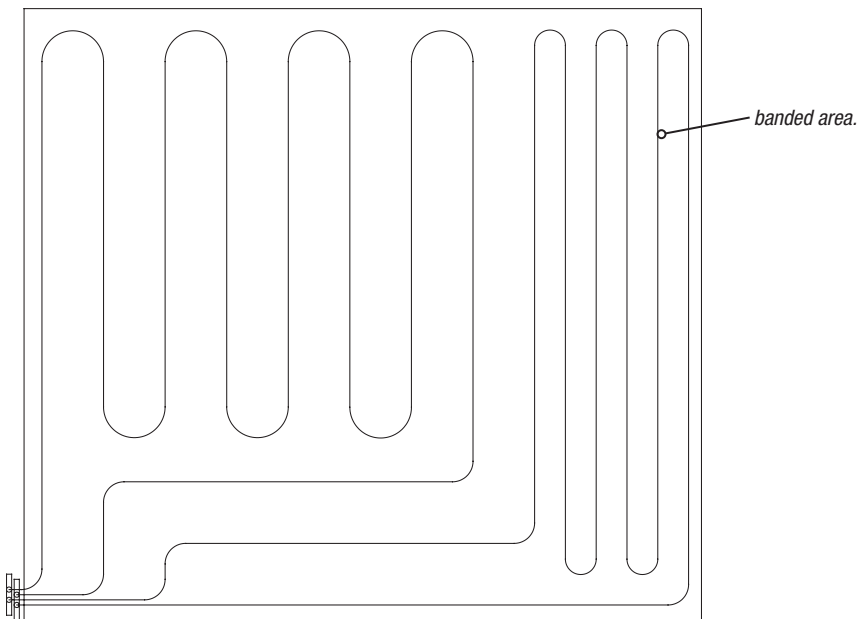

Slab

1. Pre-Pour Conditions

Verify all subgrade conditions are properly prepared, all insulation is installed according to design conditions and rewire or rebar is in place. With orange spray paint, locate all interior walls and other obstacles that may need to be avoided, such as toilet areas, sewer drains, and any structural supports that may penetrate the slab.

2. Install Manifolds

Locate where the manifolds are to be installed. Drive two pieces of rebar vertically into the ground and secure the manifolds with the use of cable ties or electrical tape. Keep the manifolds high enough to allow for the thickness of the concrete, the interior wall base plate and other structural items that may need to be installed after the pour. The temporary rebar supports may be removed after the slab is poured and ready for framing.

3. Determine Zone Boundaries

Before tubing is installed, visually inspect the area to determine the zone boundaries. This helps determine where the first circuit is to be placed, while identifying any obstacles that may be in the way.

4. Confirm Tubing Requirements

Measure the distance from the manifolds to the farthest point in the zone via right angles. Make sure the minimum circuit length is at least twice this distance. If not, the tubing will not be long enough to reach the farthest point of the zone and return.

5. Install Tubing

Pull one end of the tubing off the unwinder and attach it to the first barb of one of the manifolds. Install using a single serpentine pattern, keeping the tubing 6"-8" from the edge of the slab.

Transition sleeves should be used to protect the tubing from concrete trowels and other construction actions as it transitions from the snow melt area to the manifold location.

If installing circuits that are shorter than the boxed coil, pay attention to the footage marking on the tubing and cut at the correct length.

NOTICE

Be careful not to step on RadiantPEX-AL as placing a person's weight on the tubing may cause it to kink.

6. Secure the Tubing

Make sure all bends and corners are securely fastened to prevent the RadiantPEX+ / RadiantPERT from curling, creating an unwanted high point in the circuit. This is generally not a concern with RadiantPEX-AL.

Leave 2-5 ft. slack on each circuit in case the manifold position needs to be adjusted from its temporary location.

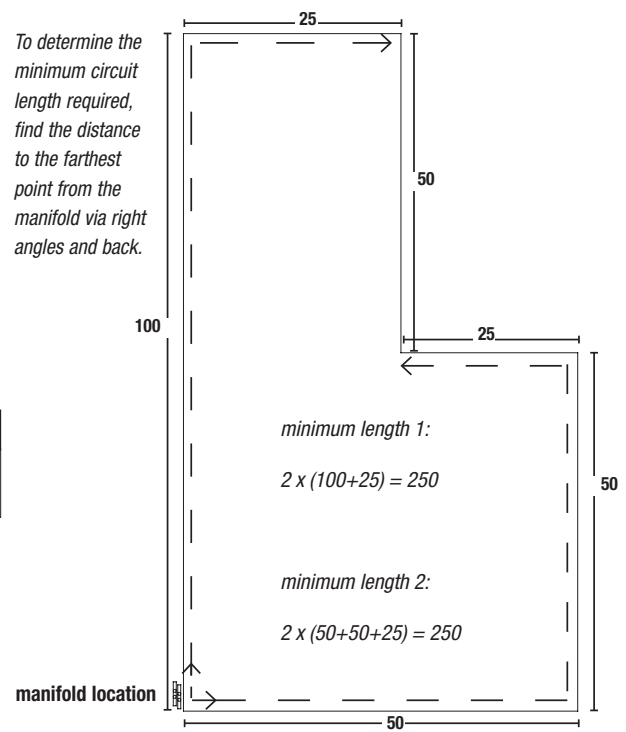
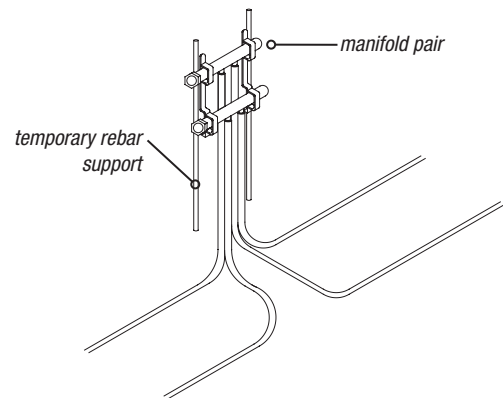
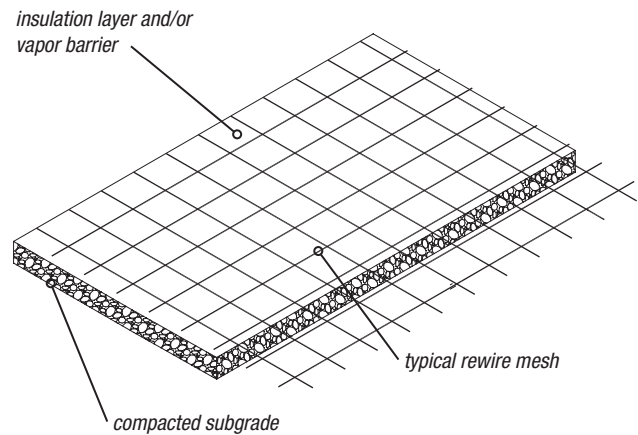

If cable ties are used, make sure all "tails" of the cable ties are either cut off or turned downward to prevent any unwanted surface protrusions.

CAUTION: Metal wire ties may increase the risk of damage to the tubing and are not an approved Watts fastener type.

Try to keep all circuits the same length. If the last circuit is too long, try not to cut it. Shorter circuits have a lower pressure drop and will tend to cause an imbalance in the fluid flow. Some tubing may be removed from this last circuit, or any previous circuit, as long as the remaining length is within 10% of the existing circuits.

7. Inspection

After all the circuits are installed, take a few minutes to walk each circuit and visually inspect the tubing for possible damage caused during installation. If damage is found, repair it using an approved Watts repair kit. Wrap the repair with electrical tape (do not use duct tape) to protect the connection from the concrete.

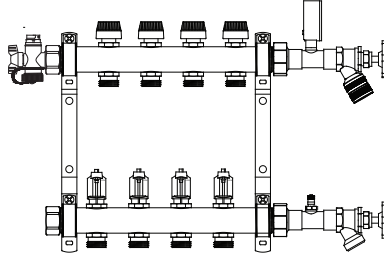

8. Pressure Test

Pressure test the system with 50-100 psi water or air for 24 hours. Do not use water if exterior temperatures are near or below freezing 32°F (0°C) conditions.

When possible, pressure test with water to 50-100 psi. If water is not present, or if freezing is a concern, air may be used. Minor pressure fluctuations (10-15 psi) are expected and are due to atmospheric temperature changes as well as potential mass thermal changes (slab curing).

9. The Concrete Pour

To help detect possible damage caused during the concrete pour, keep the system under pressure. If damage is done, locate the area in question and repair.

Some minor pressure changes will occur due to the increased internal temperatures of the concrete as it begins the curing process. Fluctuations in air temperature may also cause a slight change in the test pressure. In most cases, a 10-15 lb drop in pressure over a twenty four hour period is not uncommon.

NOTICE

1. When pressure testing a system, it is normal for the pressure to vary slightly throughout the day as air temperatures vary. For slab based systems, pressure ratings may change due to air temperature as well as thermal changes taking place within the slab.
2. Generally, a 15 psi change is not an indicator of problems. If the pressure continues to fall, then a leak may be present. Check manifold and test kit connections first then proceed to the tubing runs.

Thin-Slab Application

Most thin-slab applications are installed during the initial construction of a building, due to the increased structural requirements to carry the added weight.

Lightweight concrete products will increase the floor height by 1-1/2" and the floor load anywhere between 12 to 18 lbs/sq.ft. This increase in load usually means a modification to the joist system and/or other support modifications. It is important to verify a floor's ability to withstand these loads prior to installing a lightweight concrete product.

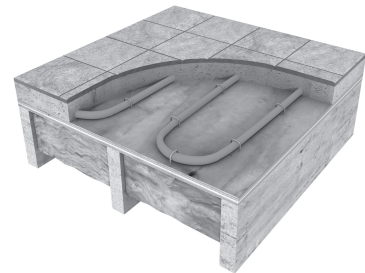

Thin-Slab

Spacing

Residential slabs will use 6", 9", or 12" tube spacing with some perimeter banding. **Do not use tube spacing wider than 12" on center in residential applications.**

In a Thin Slab over Frame Floor application, tubing is generally attached directly to the subfloor with the use of staples and/or NailTites. If the thin slab is to be installed over an existing slab, LockDowns, SnapClips, or Railways may be used to secure the tubing.

Closer spacing may be used in areas of high heat loss, such as an exposed wall with a high percentage of glass. Higher tubing densities, up to 4 inches on center, may also be used in areas that have a low thermal conductivity, such as areas with thicker than normal subfloor or dense carpet and pad.

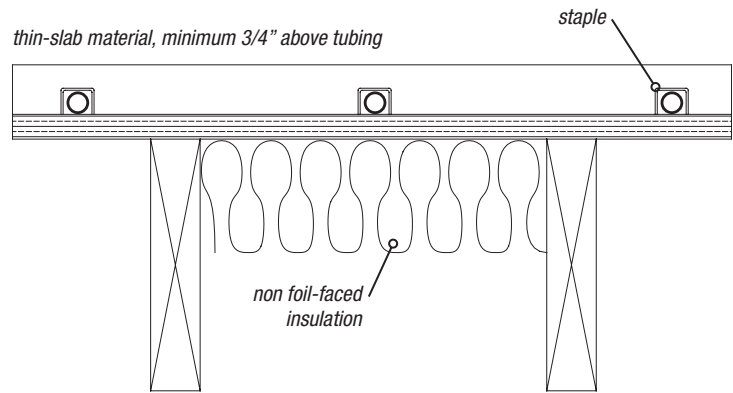

NOTICE

Tighter than 8" oc tube spacing is only possible if 3/8" tubing is used. If 1/2" or larger tubing is used on the project, a "light bulb" bend will be required.

Fasteners

The sub-material the thin-slab is installed over will determine how the tubing can be attached. The most common sub-material is a wooden subfloor.

1. Staples—spaced every 18"-24" on center. Use a staple gun set to 100 psi.
2. RailWays—used to secure 3/8", 1/2", or 5/8" tubing to various substrates. RailWays must be secured prior to the tubing being installed. 4 ft. on center spacing.

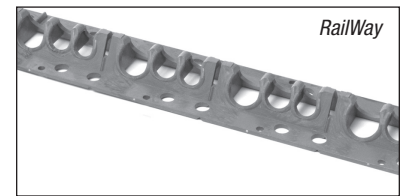
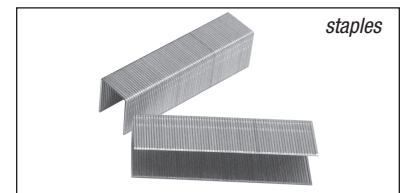

Perimeter Banding

Banding refers to any area where the tubing is installed with a closer on center spacing. Usually seen along exterior walls with higher than normal heat loss.

Thin-slab Profile

In thin-slab applications, it is important to maintain at least 3/4" of thin-slab material above the tubing. More coverage may be necessary depending on the structural requirements of the slab/structure.

Installation Steps

Manifold locations, final concrete thickness and zoning details are just a few items that can affect how a thin-slab application is installed. The following guidelines cover the most common installation conditions. If a given situation is not covered here or if unexpected circumstances arise, please contact Watts or a Watts Representative.

1. Install Manifolds

Locate where the manifolds are to be placed. With the use of Watts manifold brackets or manifold mounting enclosure, secure the manifolds to the wall. Allowances may need to be made to allow the tubing to transfer through the wall base plate and into the thin slab. Follow local code guidelines when penetrating framing base plates.

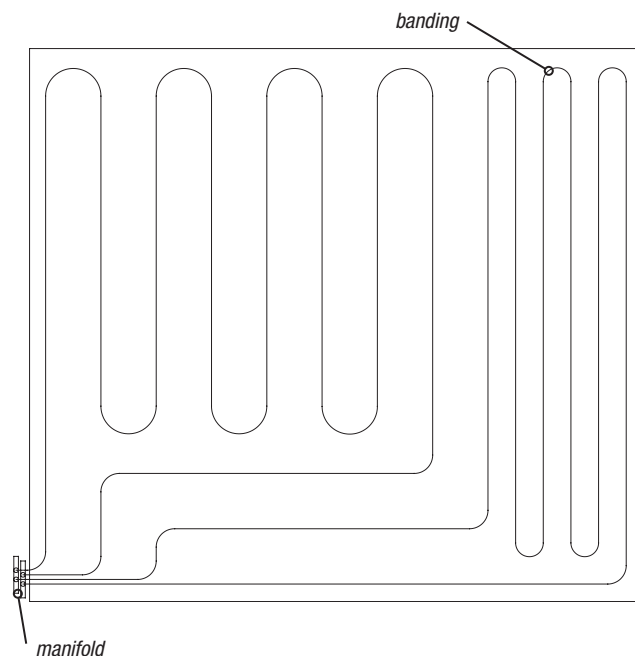

2. Determine Zone Boundaries

Before tubing is installed, visually inspect the area to determine the zone boundaries. This helps determine where the first circuit is to be placed, while identifying any obstacles that may be in the way.

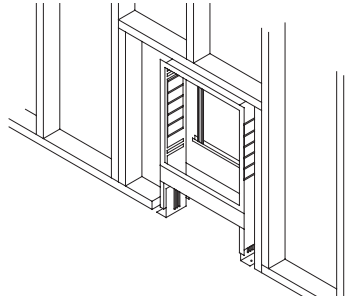

Manifold boxes are designed to be recessed into a standard frame wall. Some framing modifications may be required to accommodate the width of the manifold box.

3. Confirm Tubing Requirements

Measure the distance from the manifolds to the farthest point in the zone. Make sure the minimum circuit length is at least twice this distance. If not, the tubing will not be long enough to reach the farthest point and still have enough length to return to the manifold (see slab section for illustration).

4. Install Tubing

Place the unwinder beside the manifold with a coil of tubing. Pull one end of the tubing off the unwinder and attach it to the first barb of one of the manifolds with an approved Watts fitting.

Pull the tubing from the unwinder and lay it along the perimeter walls to the farthest point in the zone, keeping the tubing 6"-8" from the edge of the slab. This will help protect the tubing from possible penetrations later on when the final floor covering is installed.

If installing circuits that are shorter than the boxed coil, pay attention to the footage marking on the tubing and cut at the correct length.

If using RadiantPEX+ or RadiantPERT, bend supports may be used to secure the RadiantPEX+ or RadiantPERT as it transitions from the thin-slab to the wall. RadiantPEX-AL does not require a bend support.

In most thin slab applications, built-ins such as cabinets, showers and walls are already in place before the thin slab is poured. This also means these items are in place before the radiant tubing is installed.

Most structural code requirements restrict the amount of material that can be removed from a wall member. It is advised to run the tubing through doorways, or other openings, when ever possible.

5. Securing Tubing

When installing a thin-slab over a subfloor, standard staples are used. Make sure the staple gun is set to 100 psi and does not come in contact with the tubing. Secure the tubing to the floor every 18"-24".

Try to keep all circuits the same length. If the last circuit is too long, try not to cut it. Shorter circuits have a lower pressure drop and will tend to cause an imbalance in the fluid flow. Some tubing may be removed from this last circuit, or any previous circuit, as long as the remaining length is within 10% of the existing circuits.

In the event excess tubing can not be utilized, balancing control will need to be installed on the manifolds.

NOTICE

1. When installing either a thin-slab or a SubRay system, foil-faced insulation is often not needed. This is because the tubing is installed above the subfloor. Foil-faced insulation is only required if an air gap is present. In these installation methods an air gap is not present between the insulation member and the floor. If an air gap is to be created, foil-faced insulation should be used.
2. Tubing runs should avoid cutting through a wall or other structural member. When possible transition tubing from room-to-room via doorways or other opening. The only area where the wall base plate should be removed is at the manifold location.
3. If using sleepers with a thin-slab pour, make sure the thin-slab material is screed level with the sleepers. Gypsum based lightweight concretes have a tendency to shrink as they cure. This process may cause a gap to form between the sleepers, causing a reduction in heat transfer.

Thin-Slab

6. Inspection

After all the circuits are installed, take a few minutes to walk each circuit and visually inspect the tubing for possible damage caused during installation. If damage is found, repair it using an approved Watts repair kit. Wrap the repair with electrical tape (do not use duct tape) to protect the connection from the thin-slab material.

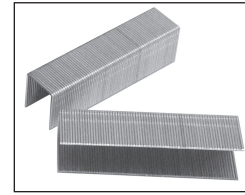

staples

7. Pressure Test

Pressure test the system with 50-100 psi water or air for 24 hours. Do not use water if exterior temperatures are near or below freezing (32°F) conditions.

When possible, pressure test with water to 50-100 psi. If water is not present, or if freezing is a concern, air may be used. Minor pressure fluctuations (10-15 psi) are expected and are due to atmospheric temperature changes as well as potential mass thermal changes (slab curing).

8. The Thin-slab Pour

To help detect possible damage caused during the thin-slab pour, keep the system under pressure. If damage is done, locate the area in question and repair.

Insulation Requirements

If the system is insulated in the joist cavity, a standard paper faced insulation can be used. Make sure to install the insulation tight against the subfloor to minimize any convective losses that may be generated. The insulation should be a minimum of 3-1/2", or R-13, fiberglass batt when the radiant floor is installed over a heated space, such as a basement. 5-1/2", or R-19, batt (or thicker, depending on the climate) should be used when the area below the radiant floor is unheated or exposed to the elements.

Thin-slab with Sleepers

Sleepers are sometimes installed within a thin slab application to allow for points of attachment for hardwood or other floor coverings.

NOTICE

The thin-slab surface must contact the upper wood floor or sub-floor. Thin slabs can shrink during curing, creating an air gap.

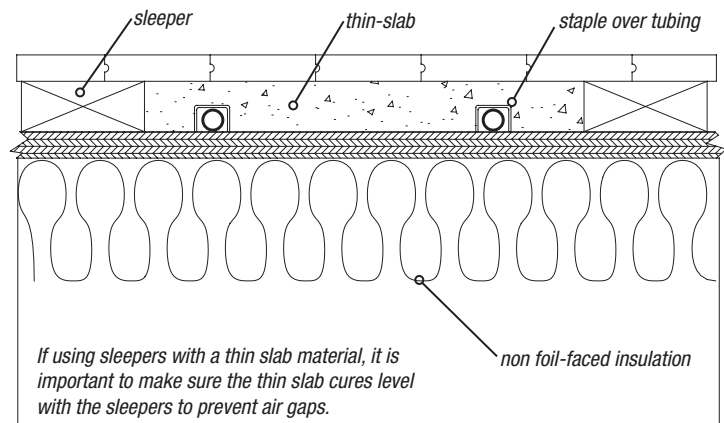
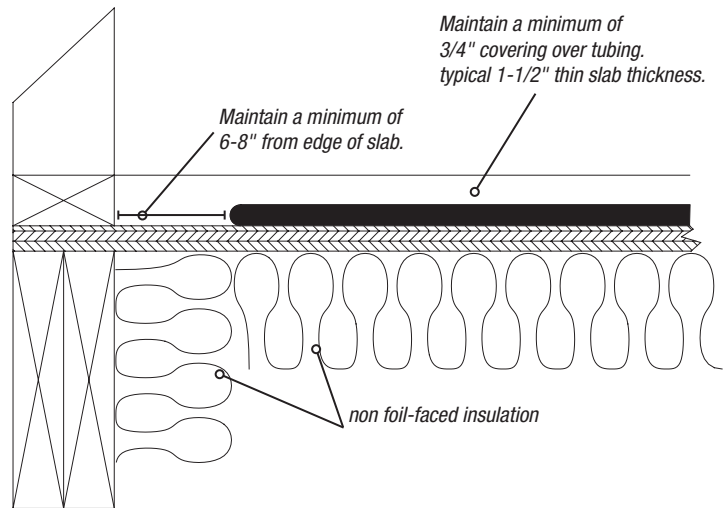

Thin-Slab

Steel Deck

Steel decks are usually seen in office mezzanines and other areas that will experience light to moderate loads. There are several different types of steel decks, ranging from 2" angle channels to 6" square channels. Attachment methods may vary depending on the construction profile and/or structural requirements.

If rewire or rebar is not to be used, install the tubing perpendicular to the ribbing on the steel deck. This will help maintain the tubing at an even depth. Due to the nature of how steel decks are made, insulation is generally placed under the steel deck.

In most deck slabs, rewire or rebar will be used, giving the installer a way to secure the tubing. In some applications fiberglass mesh will be used instead of rewire/rebar. In this case Railways may be used.

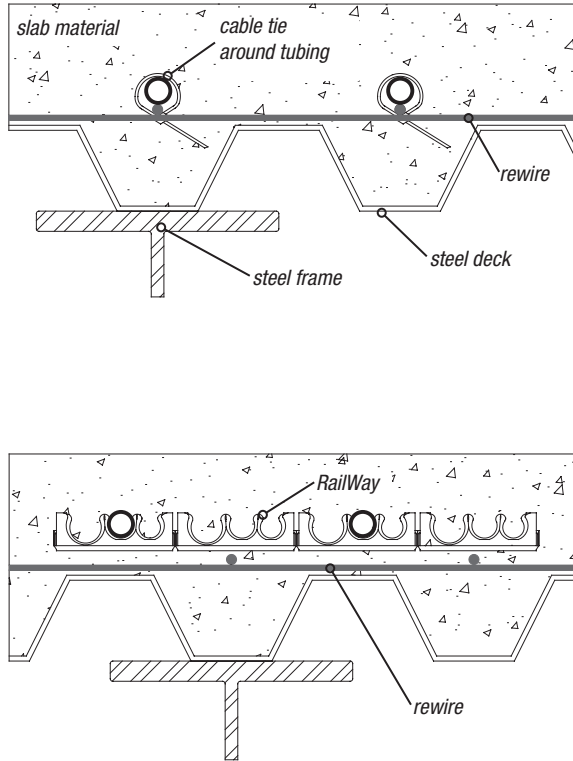

NOTICE

1. Concrete slab and brick paver applications are the two most common snow melt construction profiles. Although asphalt is discussed in this manual, it is not a recommended technique. Asphalt has a reduced conductivity value (half of concrete) and requires the tubing to be much deeper in the construction to minimize the installation conditions created by the asphalt pour.
2. Most snow melt systems do not require horizontal insulation. This is due to the common structural loading caused by vehicular traffic on the snow melt area. In some conditions, vertical insulation may be used to help isolate horizontal heat losses, especially where landscaping is concerned.

Snow melt Application

Snow melt applications are used whenever a snow or ice free exterior surface is desired. Various design considerations may greatly effect the overall system design. Before installing a snow melt system, make sure all design considerations are accounted for and approved.

There are three main application profiles for a snow melt system: concrete slab, brick paver, and asphalt.

Slab-on-Grade

Radiant snow melt and ice removal systems for concrete and brick pavers are installed in the same manner as shown for a standard concrete slab. Refer to the Slab-on-Grade section of this manual for specific slab installation details.

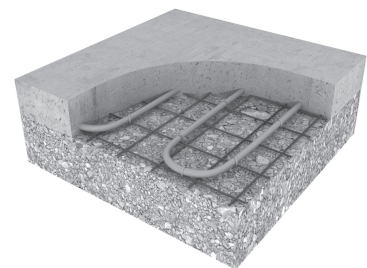

Snow melt

Brick Paver

Tubing can be installed in a sand, stone dust, or concrete layer underneath the brick pavers for the purpose of snow melting.

The thickness of the paving bricks must be selected according to the manufacturer's printed cautions and load limitations. Bricks not thick enough to support the design load will crack and/or shift in service.

There are two general types of installations for tubing installed under brick pavers:

1. Concrete

Tubing is embedded in the slab, and the bricks are adhered to the top of the slab. Consult with experts in the field to ensure that the correct adhesives are used to secure the bricks to the concrete, and the slab will meet the load requirements of the expected traffic.

2. Base Material

Tubing may be imbedded in the base material. A minimum of 1" covering must separate the tubing from the paver.

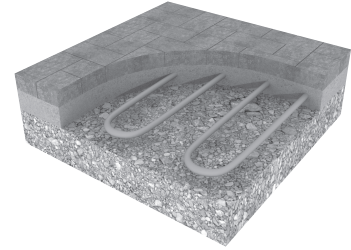

Asphalt

Although it is possible to install a snow melt system in asphalt, special considerations are required beyond what is described later in this section.

1. The tubing must be installed in the sub-base material with a minimum of 2" of covering. Sub-base is typically compacted crush stone, but may vary depending on structural design considerations.
2. Generally, higher water temperatures are required to drive the heat through the stone and asphalt covering. This may result in a lower overall BTU capacity.

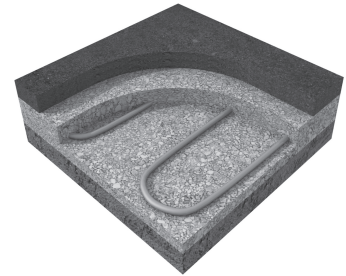

General Guidelines

The following guidelines are universal for all application types, except where noted.

Fasteners

Tubing can be attached to either the rewire, rebar or below slab insulation. Each of the following can be used, depending on installation requirements.

1. CableTies—nylon cable tie used to secure all sizes of tubing to either rewire or rebar. 12"-18" on center.
2. ScrewClips—used to secure 3/8" or 1/2" tubing to foamboard insulation. 18"-24" on center.
3. Foamboard Staples—used to secure 3/8" or 1/2" tubing to either foamboard or tarp insulation. 18"-24" on center.
4. RailWays—used to secure 3/8", 1/2", or 5/8" tubing to various substrates. RailWays must be secured prior to the tubing being installed. Every 4 ft on center.

It is important to follow all associated guidelines for a particular attachment method to prevent the tubing from shifting during the installation.

General Site Preparation

Snow melt systems should be placed on well compacted material, consisting of rock or sand. Load issues need to be discussed with a structural engineer or the project supervisor.

The snow melt area must be designed with drainage in mind. Water will run off of the snow melt area in the same manner as rain. External run-off areas outside the snow melt zone may be blocked by snow, ice, or slush. Drain locations and run-off profiles need to be designed with winter conditions in mind. In some cases, extra tubing may need to be installed around drain lines to prevent water from freezing.

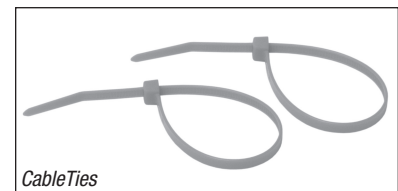

CableTies



ScrewClip

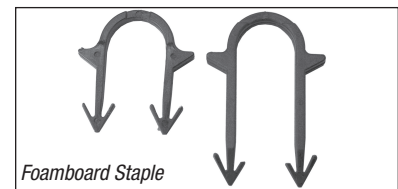

Foamboard Staple

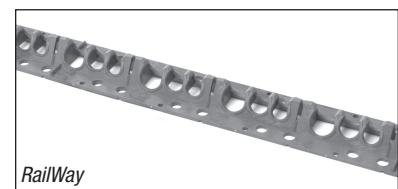

RailWay

Snow melt

A radiant slab should never be placed directly on top of solid bedrock, as this material can rapidly conduct heat from the slab into the earth. Insulation must be installed between the slab and rock.

One to two inches of sand may be placed on top of the coarser base rock material. This gives a smooth, level surface to lay down rigid insulation (if necessary), and helps prevent possible breakup of the rigid insulation in high traffic areas prior to concrete/paver placement. The sand layer also allows for more precise leveling to minimize any variation in the slab thickness.

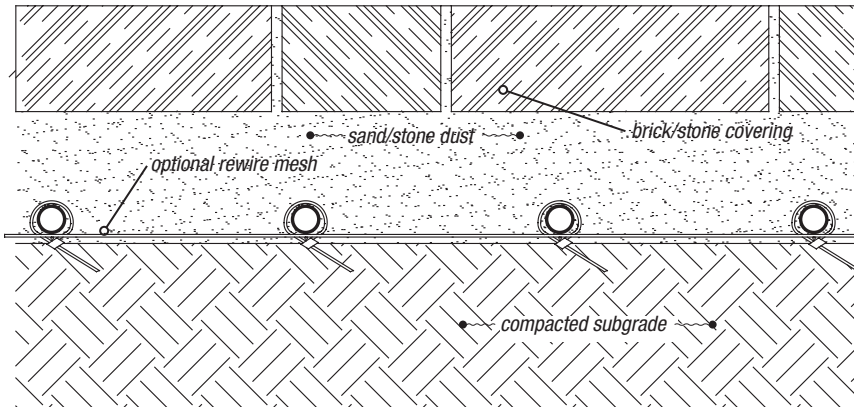

Rewire may be used to help secure tubing before the sand/stone dust layer is added.

NOTICE

Check with local building codes to see if they allow the use of sand directly underneath slabs.

Insulation Details

Unlike interior slab applications where the insulation is recommended, snow melt systems may not require insulation. This is due to:

1. Loading

Snow melt areas will experience higher loads than standard interior heating applications. Heavy vehicular traffic, such as tractor-trailers, may cause the insulation to compress. This compression increases the risk of cracking in a slab.

2. Heat Transfer

Heat moves to cold. The coldest point of a snow melt system is the surface. Heat will naturally move more towards the surface than to the ground below.

This is not to say insulation cannot or should not be used on a snow melt system. Areas that need a faster response or are more hazardous will benefit from insulation. Stairs, handicap access ramps and sidewalks are a few areas which may benefit from insulation.

NOTICE

If insulation is used, it must be used for the entire zone. Thermal capacities between an insulated area is greatly different from non-insulated areas, resulting in possible re-freeze conditions.

If insulation is to be used, a non-foil faced, high-density, extruded polystyrene (such as Dow® Blue Board®) or an insulative tarp should be used.

The use of a foil-faced insulation is not required or recommended when insulating a snow melt slab. Foil-faced insulation is used when an air gap is maintained between the tubing and the insulating member. In the case of a snow melt slab or brick paver application, the tubing is completely encapsulated in the bedding material, eliminating any air gap. In addition, concrete will tend to degrade exposed foil over time.

NOTICE

For the most part, the installation process for a snow melt application is very similar to that seen for a standard slab-on-grade heating application. The main variance is the tubing depth. Due to vehicular loading, a minimum depth may be 3" instead of the previously discussed 2" for heating applications.

Snow melt

NOTICE

Watts does not advise the use of Bubble-type insulation under a slab application until more research has been done and performance has been verified. If needed or specified by a structural professional, use only extruded polystyrene, such as Dow® Blueboard® or equivalent. Density and thickness should be specified by a professional.

Control Joints

Concrete slabs will expand and contract due to thermal changes. To prevent damage to the slab, expansion joints are used to control this movement. In some cases cut joints are used to control and direct cracking. Make sure the tubing is protected according to the requirements of the control joint.

Spacing and Tubing Requirements

Most snow melt systems will use 9-12" tube spacing. Certain areas, such as steps or in front of door openings, may be installed on 6" centers. **Do not use tube spacing wider than 12" on center in snow melt applications.**

Due to the increased pumping requirements for the higher loads, a larger diameter tubing is needed to keep an acceptable pressure drop.

Installation Requirements

Manifold locations, final concrete or sand thickness and zoning details are just a few items that can affect how a snow melt application is installed. The following guidelines and examples

Landscaping boxes are frequently used to house manifolds for exterior applications.

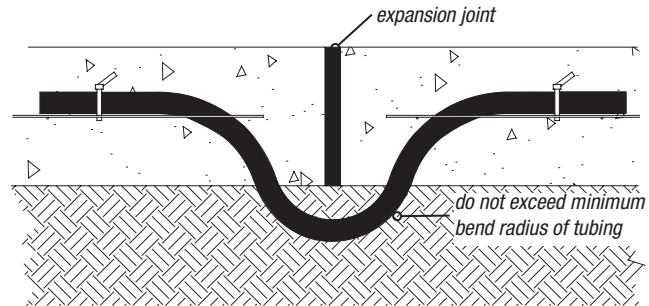
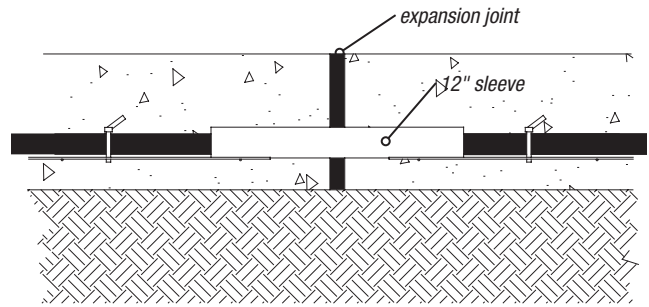

Expansion joints can be installed in several ways, depending on slab construction requirements. If a sleeved approach is to be used, make sure the sleeve extends at least 6" to either side of the joint. Rigid PVC or a similar material should be used for the sleeve.

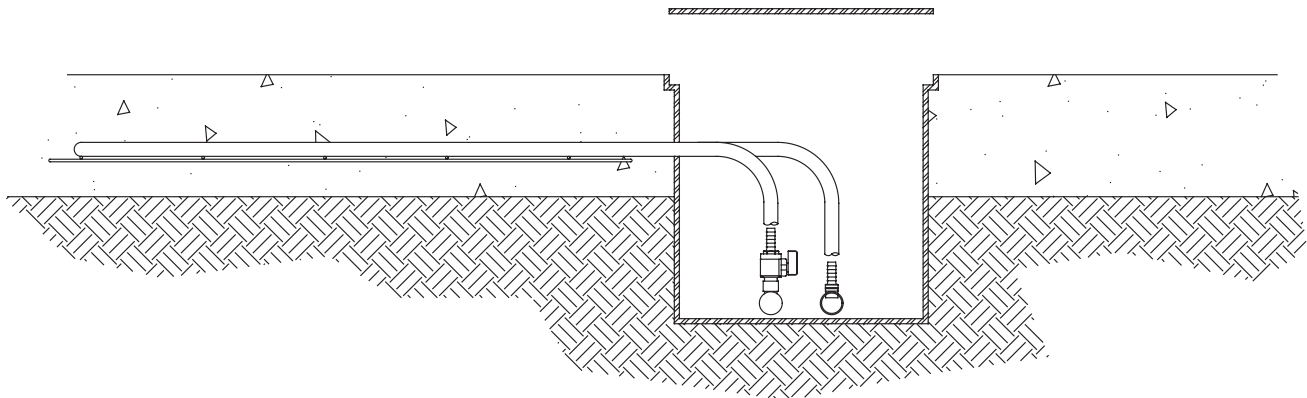

cover the most common installation conditions. If a given situation is not covered here or if unexpected circumstances arise, please contact Watts or a Watts Representative.

1. Pre-install Conditions

Verify all subgrade conditions are properly prepared, all insulation (if necessary) is installed according to design conditions and rewire or rebar is in place. With orange spray paint, locate any obstacles that may need to be avoided. These may include trench drains or other structural supports that penetrate the slab, such as hand rails.

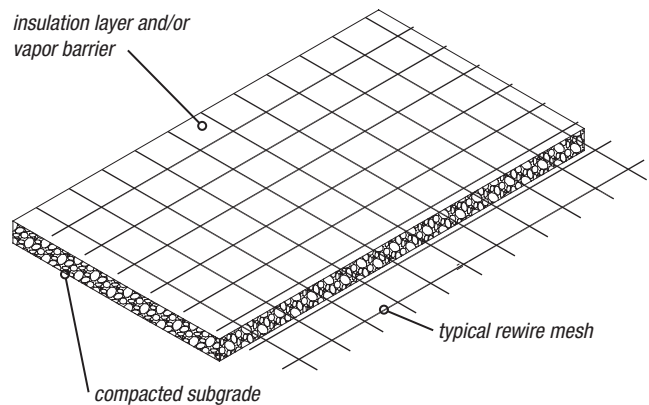

Snow melt

2. Install Manifolds

Locate where the manifolds are to be installed. In most snow melt systems, the manifolds will be located in an environmentally resistant box and placed in the ground. Some applications may allow the manifolds to be mounted in a structural wall, such as in the exterior wall of a garage. With either method, it is important to support the manifolds in such a way so they are not damaged during the concrete or paver installation.

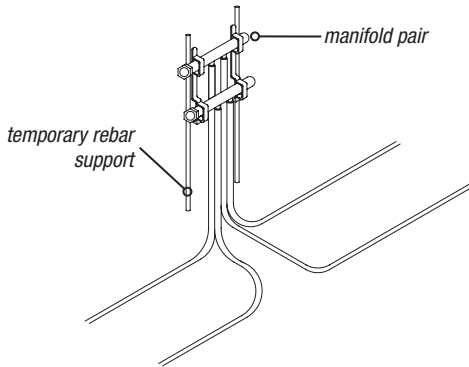

3. Determine Zone Boundaries

Before tubing is installed, visually inspect the area to determine the zone boundaries. This helps determine where the first circuit is to be placed, while identifying any obstacles that may be in the way.

4. Confirm Tubing Requirements

Measure the distance from the manifolds to the farthest point in the zone. Make certain the minimum circuit length is at least twice this distance. If not, the tubing will not be long enough to reach the farthest point and still have enough length to return to the manifold.

NOTICE

NOTE: Drainage conditions are a concern for snow melt applications. Make sure proper drainage is provided to help carry away the water generated by the melting snow. Improper drainage may result in surface ice formation (black ice) or unwanted ice build-up.

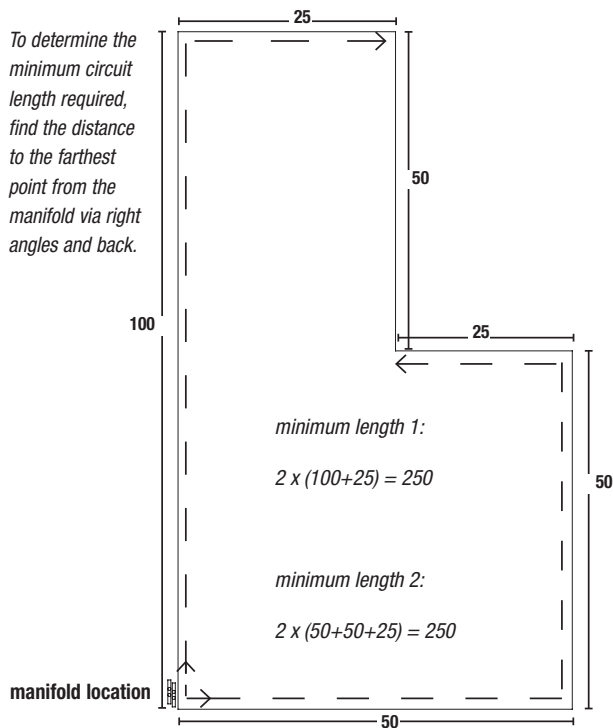

Snow melt

5. Install Tubing

Pull one end of the tubing off the unwinder and attach it to the first barb of one of the manifolds. Install using a single serpentine pattern, keeping the tubing 6"-8" from the edge of the slab.

Transition sleeves should be used to protect the tubing from concrete trowels and other construction actions as it transitions from the snow melt area to the manifold location.

If installing circuits that are shorter than the boxed coil, pay attention to the footage marking on the tubing and cut at the correct length.

NOTICE

Be careful not to step on RadiantPEX-AL as placing a person's weight on the tubing may cause it to kink.

Make sure the tubing is the same depth in the concrete, sand or stone layer. Unequal depth may result in uneven surface melting.

6. Securing Tubing

Try to keep all circuits the same length. If the last circuit is too long, try not to cut it. Shorter circuits have a lower pressure drop and will tend to cause an imbalance in the fluid flow. Some tubing may be removed from this last circuit, or any previous circuit, as long as the remaining length is within 10% of the existing circuits.

In the event excess tubing can not be utilized, balancing control will need to be installed on the manifolds.

Make sure all bends and corners are securely fastened to prevent the tubing from curling, creating an unwanted high point in the circuit. Leave 2-5 ft. slack on each circuit in case the manifold position needs to be adjusted from its temporary location.

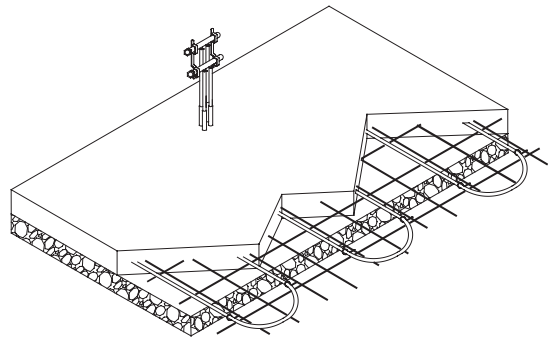

CAUTION: Metal Wire ties may increase the risk of damage to tubing and are not an approved Watts fastener type.

7. Inspection

After all the circuits are installed, take a few minutes to walk each circuit and visually inspect the tubing for possible damage caused during installation. If damage is found, repair it using an approved Watts method. In the event of extensive damage, a Watts Repair Kit may be required. Wrap the repair with electrical tape (do not use duct tape) to protect the connection from the slab material.

8. Pressure Test

Pressure test the system with 50-100 psi water or air for 24 hours. Do not use water if exterior temperatures are near or below freezing 32°F (0°C) conditions.

9. The Concrete/Paver Install

To help detect possible damage caused during the concrete pour, keep the system under pressure. If damage is done, locate the area in question and remove the section of tubing from the concrete. Clean off the damaged area and install a Watts splice fitting. Wrap the fitting with electrical tape to protect it from the concrete. Bring the circuit back up to pressure to ensure a proper fit on the splice.

Some minor pressure changes will occur due to the increased internal temperatures of the concrete as it begins the curing process. Fluctuations in air temperature may also cause a slight change in the test pressure. In most cases, a 10 - 15 lb drop in pressure over a twenty four hour period is not uncommon.

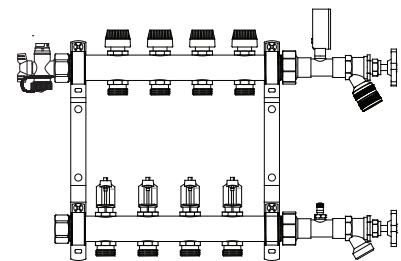

When possible, pressure test with water to 50-100 psi. If water is not present, or if freezing is a concern, air may be used. Minor pressure fluctuations (10-15 psi) are expected and are due to atmospheric temperature changes as well as potential mass thermal changes (slab curing).

Steps

There are two important areas to keep in mind when installing steps in a snow melt application.

1. Tread Area
2. Riser Area

These two areas are where ice and snow will have the greatest build up. The edge of the tread is where the least amount of melting will take place since it will be the farthest from the tubing. It is also the area that will cause the most hazards. When selecting an installation technique, keep these factors in mind.

The finished covering may also influence which installation method is used; for example a standard slab versus a stone cap over the slab. In addition, the riser height will be a factor in determining how much tubing can be installed.

Tubing can be installed either parallel or perpendicular to the step treads.

Perpendicular installations allow the tubing to run along the natural contour of the step. This installation technique is used mostly with RadiantPEX-AL. RadiantPEX+ or RadiantPERT may be installed in this fashion if the step design allows for the required bend radius to be used.

vertical installations

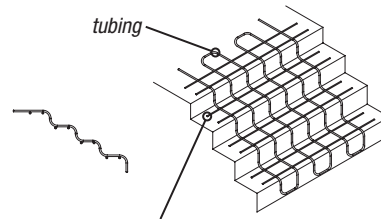

typical rebar configuration for poured steps

Vertical tubing installations may require a tight bend radius to accommodate the step configuration. Make sure this type of installation does not exceed the minimum bend radius of the tubing type.

horizontal installation

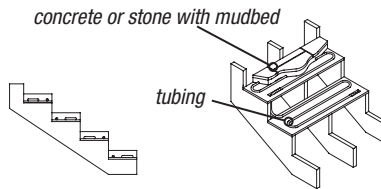

Horizontal installations may or may not use a frame with an over-pour. Rebar may be used in a similar fashion as shown in the vertical installation method with the tubing running horizontal. Construction and tubing installation will change base on structural requirements.

NOTICE

Step applications require the tubing to be installed in a fashion that is in compliance with the minimum bend radius of the tubing. RadiantPEX-AL will allow for a tighter bend radius and may be more acceptable for step applications.

It is important to try and keep the tubing at a uniform depth throughout the step construction. Variations in tubing depth may result in uneven melting.

Any time glycol is used in a system, it is important to set up a yearly maintenance program. This program should test the system pH as well as the freeze point of the fluid. Glycol systems will require a flush and re-fill after a period of several years. Proper maintenance will help prolong this process.

Note: Watts does not

recommend laying the tubing along the bottom of the step installation. This type of install places the tubing too far from the edge of the riser, creating an uneven melted surface condition.

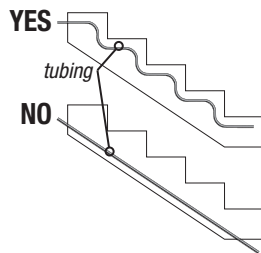

Parallel installations may be somewhat more complicated to install, but they offer the most melting potential. This approach will more easily melt snow and ice that may build up along the outer step edge. It is important not to exceed the minimum tube bend radius for the tubing when transitioning from step to step.

In both applications it is important to keep the tubing 2" to 3" away from the surface of the concrete, or final step material.

In some cases it may be ideal to install a designated manifold for the steps. This allows for a dedicated vent/purge assembly to be used for purging the tubing located in the steps.

Snow melt

Glycol

Any hydronic system that is exposed to near or below freezing conditions must have propylene glycol installed as the working fluid. Propylene glycol can prevent the system fluid from freezing. The level of freeze protection will depend on the glycol concentration used.

typical refractometer used to measure glycol freeze point.



Glycol Basics

Glycol is naturally corrosive. Buffers and inhibitors are added to offset this corrosive effect. In addition, glycol acts like an “oxygen grabber”, absorbing any free oxygen molecules in the system. The more oxygen the glycol “grabs”, the more acidic it will become.

Systems should not be operated at levels below 30% glycol.

Glycol levels below 25% do not contain enough corrosion inhibitors and may cause the glycol to act as food, allowing microbes to grow. The microbes feed, grow and die, creating a black sludge material in the system. Propylene glycol concentrations above 25% prevents microbe growth. Try not to exceed a mixture level greater than 70% as the fluid may become too viscous (thick) for the circulators.

As glycol in the system ages, the inhibitors and buffers contained in the system begin to break down. This process slowly returns the system to the natural pH level of the glycol. If not properly maintained, glycol will cause corrosion. Check a glycol system at least once a year to ensure the glycol is still within its operating parameters.

Glycol Maintenance

A glycol system should be checked for two things: system pH and freeze protection. The quickest way to check a glycol system’s pH is with litmus paper. If the pH drops below 7, then more buffers must be added to a system or the system needs to be flushed and refilled. There are only a limited number of times buffers can be added to a system before it must be flushed and replaced. Check with the glycol manufacturer for further details. Some glycol manufacturers will require a higher minimum pH to be maintained.

The second item that must be checked in a glycol system is the actual level of freeze protection provided. Watts recommends a 30-50% glycol solution. However, a 50% anti-freeze solution and 50% water does not always equate to a 50% solution. Different glycol providers supply different concentrations of glycol and/or may mix a certain amount of distilled water with the inhibitors.

The only way to accurately measure the percentage of glycol in a system is to use a refractometer. A refractometer determines the freeze point of a liquid by measuring the angle through which light is bent (the angle of refraction) as it passes through the liquid. This angle is a direct correlation to its freeze point.

This should be checked before and after the glycol is added to the system. Check a sample mixture, one cup glycol and one cup water. Test this solution with the refractometer to see what the system freeze protection will be. Do this each time the system is re-filled with new glycol. Also, check the freeze protection when the system pH is checked just to make sure the system is operating within the desired parameters.

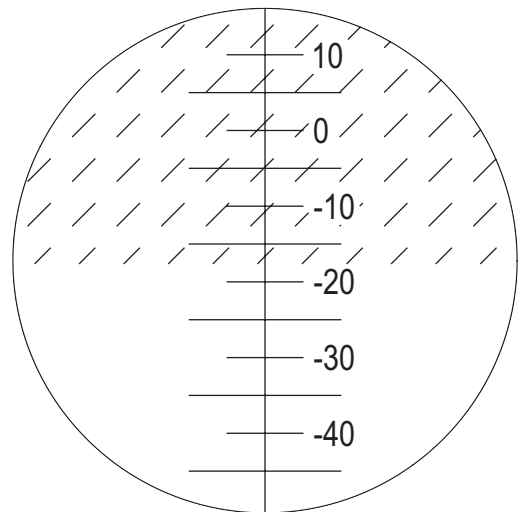

NOTICE

The refractometer used must be calibrated for propylene glycol. A refractometer calibrated for automotive (ethylene) glycol will not yield accurate results.

Manifolds

Manifold options vary depending on the desired goal and construction needs. Options may include balancing, flow control, connection, material type, as well as space considerations. The following are the most common manifold types/styles offered by Watts. Custom manifolds can be designed and built to any project/construction specification. Contact Watts for further information on custom manifolds.

Watts Manifold Types

Manifold types include Custom Tubular, CustomCut, Swedged, and Stainless Steel. Additions and omissions to manifold options may occur. Please reference the current product catalog for a full list of available manifolds.

Custom Tubular Manifolds

Custom Tubular manifolds are custom built to customer specifications. This includes base pipe sizes from 1" and larger, circuit and base trunk ball valve configurations, base unions, vent/purge assemblies, as well as tubing connection types.

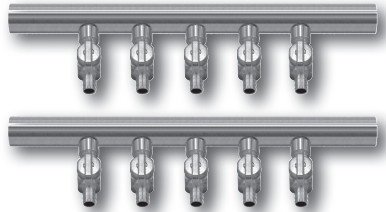

Custom Tubular manifolds

CustomCut™ Manifolds

CustomCut manifolds are 4 ft. sticks with either 12 branches with 4" spacing or 16 branches with 3" spacing. Stand alone vent/purge assemblies are available for field installation. CustomCut base trunks are available from 1" and larger.



CustomCut manifolds

Swedged Manifolds

Swedged manifolds are 3 and 4 branch segments designed to "link" together via the flared, or swedged, end. Manifold base trunks are 1" and are available for all fitting types and include all accessory items such as vent/purge assemblies and circuit ball valves.

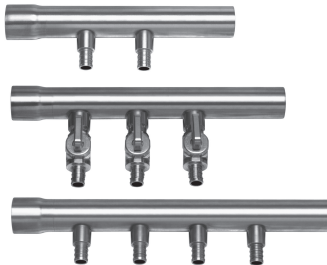

Swedged manifolds

Stainless Steel Manifolds

Stainless Steel manifolds are available with either 1" or 1-1/2" base trunks. Each set comes standard with manifold mounting brackets, internal balance valves, and flow meters. Accessory items include vent/purge assembly, trunk isolation valves, and pressure differential by-pass.

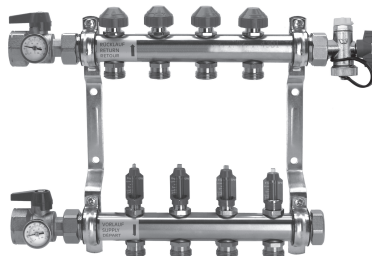

Stainless Steel manifold

Field constructed manifolds may be used in lieu of a pre-fabricated manifold. When constructing a manifold, be sure to use Watts tubing connections and fittings.

NOTICE

Manifold options should be chosen based on system flow and control needs. All manifold options are available with any RadiantPEX+, RadiantPERT, or RadiantPEX-AL connections systems. Larger commercial manifold quotes are available upon request.

Manifolds

Manifold Setup

Manifolds can be setup in one of several ways: Direct Piping, Manifold Reverse-Return, Tubing Reverse-Return, and Long Manifold.

Direct Piping Configuration

Direct Piping is the simplest format to set up. Supply and return lines connect to the same side of the manifold and circuit lengths connect to the manifolds in the same sequence. This method generally requires more post installation balancing.

Manifold Reverse-Return Configuration

Reverse-return piping uses piping methods to generate a balanced flow condition by equalizing the pressure drop generated through the manifold. A Manifold Reverse-Return configuration positions the manifolds in opposite directions, allowing for the supply line to enter on one side and the return line on the other. Individual circuits are then oriented from the first barb on the supply and return manifolds.

Tubing Reverse-Return Configuration

Tubing Reverse-Return uses the same piping logic as seen with a Manifold Reverse-Return configuration with a few modifications. The base manifold is oriented in the same direction with the supply and return lines connecting on the same side. The reverse-return format is achieved by connecting the circuits to the first available barb on the supply manifold and to the last barb on the return.

Long Manifolds

Long Manifolds are generally field constructed manifolds. The concept with a Long Manifold is to spread the tubing connections out over a longer span instead of bringing all of the tubing back to one location. This can be especially beneficial on a commercial project where the length of tubing required to come back to a single point is longer than the pumping capacity can allow. A Long Manifold configuration simplifies the connection and reduces the individual circuit length.

Since Long Manifolds generally take up the entire length of a wall it is somewhat less feasible to have supply/return connection at opposite ends. To provide single-side connection and reverse-return, a third manifold leg is used.

If using a Long Manifold approach without reverse-return, it is imperative balance valves are used for each circuit.

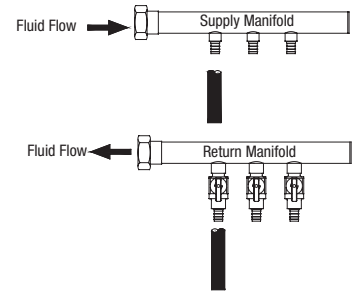

direct piping configuration

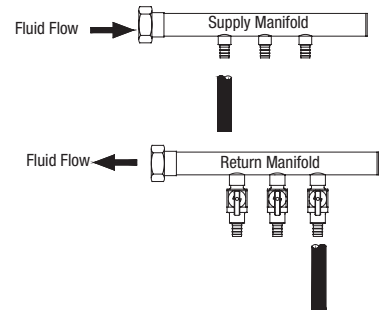

tubing reverse-return piping configuration

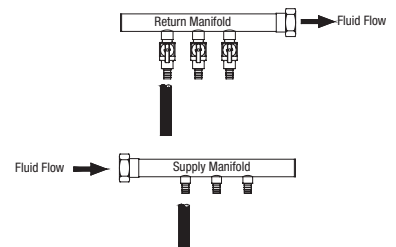

manifold reverse-return piping configuration

Long manifolds use a third manifold leg to generate reverse return while allowing for single-side connections for the supply and return lines.

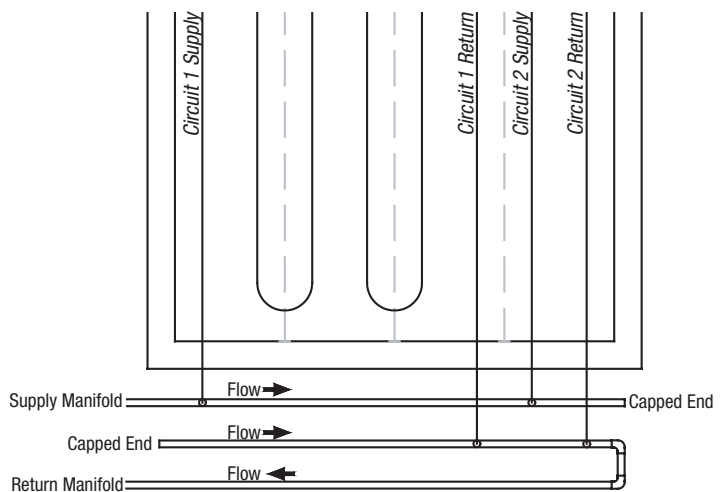

Supply & Return Piping

WattsPEX, RadiantPEX+, RadiantPERT, and RadiantPEX-AL tubing offers a unique solution to a common problem associated with baseboard and fan coil systems. Running supply and return lines to these units can be a challenge, especially in renovation projects. Different techniques may be used to connect RadiantPEX+, RadiantPERT, or RadiantPEX-AL to baseboard, fan coils, or manifolds depending on component orientation. It is important to prevent the tubing from exceeding its minimum allowable bend radius. If this radius can not be maintained, a copper elbow should be hard piped to the unit prior to the installation of the RadiantPEX+, RadiantPERT, or RadiantPEX-AL barb fitting.

CAUTION: In order to prevent pipe damage, do not exceed 200°F at 100 psi for RadiantPEX-AL, 200°F at 80 psi for RadiantPEX and RadiantPEX+, and 180°F at 80 psi for RadiantPERT.

Making Connections

1. Choose the correct tubing size for the design flow rate and run length. See the appendix for flow rate and pressure drop values.
2. Choose the corresponding fitting (CrimpRing, Press, or Compression).
3. Solder the barb or elbow onto the baseboard, fan coil unit, or manifold. If an elbow is required, install this prior to installing the barb. Follow all connection steps and procedures described earlier in this manual.
4. Complete the connection according to the fitting style used. See corresponding sections of the manual for more details on how to make a connection.

NOTICE

1. Supply and return lines for baseboard or fan coil systems are a great use for RadiantPEX+, RadiantPERT, or RadiantPEX-AL tubing.
2. Watts also offers a pre-insulated PEX product, R-flex, which is suitable for direct burial. See the R-flex Install and Design manual for more details..

Type	Size	Crimp	Cinch	Compression	Press
RadiantPEX+ & RadiantPERT	1"	✓	✓	✓	
	1-1/4"	N/A			
	1-1/2"				
	2"				
RadiantPEX	1-1/4"	✓			
	1-1/2"	✓ *		✓	
	2"			✓	
RadiantPEX-AL	1"			✓	✓
	1-1/4"	N/A			
	1-1/2"				
	2"				

* 1-1/2" crimp uses a powered tool

Large Diameter Compression Fitting

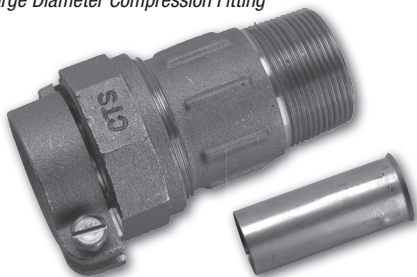

Connection Options

RadiantPEX+, RadiantPERT, and RadiantPEX-AL connections for 1" tubing are the same as described in the beginning of the manual. RadiantPEX sizes 1-1/4", 1-1/2", and 2" uses either a CrimpRing or a Compression Connection.

Supply & Return Piping

Support RadiantPEX or RadiantPERT within 6" on either side of a bend with StrapDowns or SnapClips. Supports need to be placed every 32" when hanging RadiantPEX or RadiantPERT in a horizontal position. Use Mid-run Bend Supports where necessary to ensure straight, non-stressed entry into the fitting.

Support RadiantPEX-AL within 6" on either side of a bend with StrapDowns or SnapClips. Supports need to be placed every 48"-60" maximum when hanging RadiantPEX-AL in a horizontal position. Bend supports are typically not required with RadiantPEX-AL.

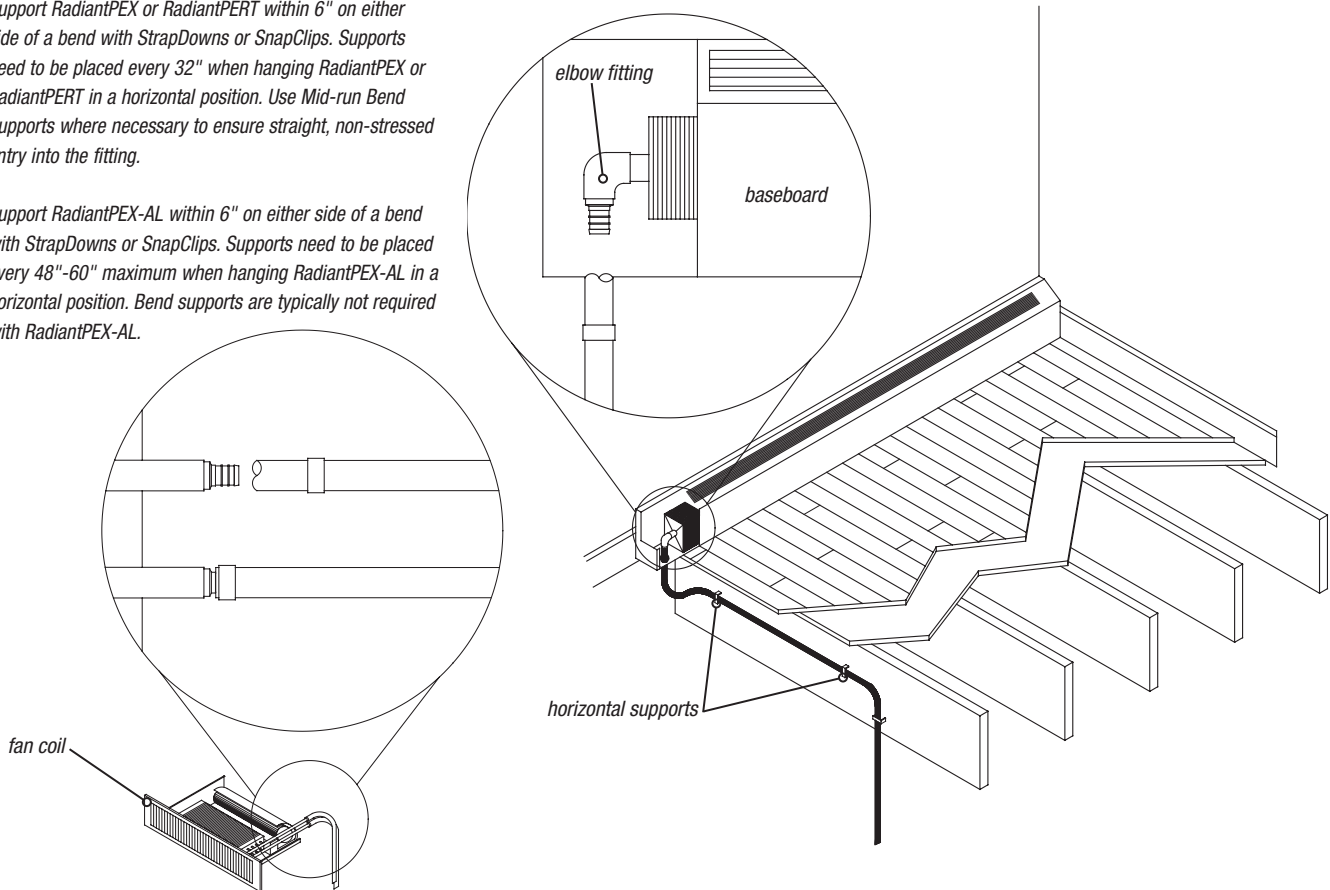

CrimpRing Connections

CrimpRing connections require a powered CrimpRing Tool. Compression connections require the use of the insert stiffener (included with the fitting).

Compression Connections for 1-1/2" and 2" RadiantPEX

1. Make sure the PEX pipe is round, not flattened, with a square cut. Clean off any dirt or corrosion so that pipe surface is smooth.
2. Place the Insert Stiffener in the end of the PEX pipe. Slide the PEX into the Split Clamp end of the joint and past the EPDM Rubber Gasket to the base of the socket. Failure to do so may result in a leak.

If the nut or socket appears too large or too small for the PEX pipe, verify the correct fitting is being used

3. Tighten the Pack Nut to secure the internal EPDM against the PEX pipe. Tighten the nut 1 to 1-1/2 turns past snug

NOTICE

Do not use a pipe wrench.

4. Firmly tighten the Split Clamp Screw with the use of a socket or box wrench

NOTICE

Do not use a screwdriver

5. Always pressure test for leaks when connection is complete.

Large Diameter Compression Elbow

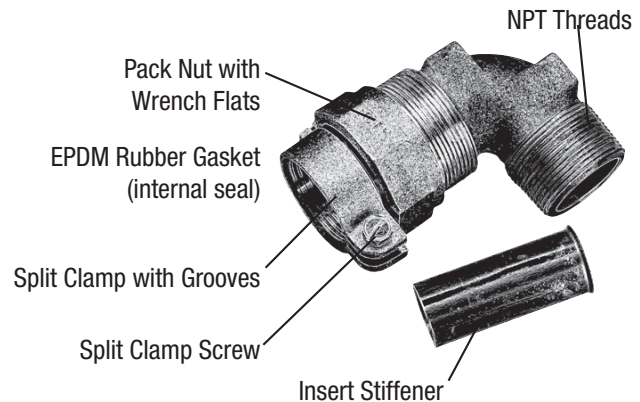

⚠ WARNING:

1. Brass fittings can be damaged by improper handling. Do not drop. Protect threads. Avoid loose fitting wrenches
2. Always use the Insert Stiffener when using PEX pipe.
3. Inspect and test all joints for leaks before backfilling or covering.
4. Do not test or operate at pressures higher than 100 psi.
5. For hydronic heating and snow melting applications only.

NOTICE

Do not use on gas lines. Installation on gas lines can result in serious injury or death.

Pressure Drop Charts

Pressure Drop Methodology

Calculating pressure drop through a tube or circuit is dependent on a wide range of factors – viscosity, density, flow rate, and tube conditions. Pressure drop (loss) in the circuits is determined using the Darcy-Weisback equation. These equations are referenced in ASHRAE's 2005 Handbook - Fundamentals, section 2.0, equations 5, 18, 30, 32a, 32b, and 32c.

Glycol values referenced are based on DowFrost™ Technical Specification (form no. 180-01272-402AMS). Different glycol concentrations, types, and formats will result in different pressure drop calculations. The data points provided should only be used as a reference point.

Data

DowFrost™ 50% Solution (extrapolated data)			
°F	Density (lbs/cu.ft.)	Dynamic Viscosity (cps)*	Dynamic Viscosity (lb-ft-s)
40	65.670	14.280	0.0096
60	65.210	12.394	0.0048
80	64.750	10.509	0.0029
100	64.290	8.623	0.0020
120	63.830	6.737	0.0014
140	63.370	4.851	0.0011
160	62.910	2.966	0.0009
180	62.450	1.080	0.0007

* derived equation used for extrapolation: $y = 8473.8x^{(-1.7307)}$

The table shown assume an approximate mixture of water/glycol of 50% concentration. Actual pressure drop values will change depending on actual concentrations and fluid temperature.

Water			
°F	Density (lbs/cu.ft.)	Dynamic Viscosity (cps)	Dynamic Viscosity (lb-ft-s)
80	62.22	0.858	0.00058
100	61.99	0.681	0.00046
120	61.71	0.557	0.00037
140	61.38	0.466	0.00031
160	61.00	0.398	0.00027
180	60.58	0.345	0.00023

Calculations

Where:

- HL = Head Loss in feet per 100 feet of pipe
- f = Friction factor
- L = Length of pipe (ft)
- V = Fluid velocity (ft/sec)
- d = Pipe inside diameter (ft)
- g = Gravity (32.2 ft/sec²)
- Re = Reynold's number
- e = Pipe roughness factor (est. 3.0E-6)

$$HL = f \left[\frac{LV^2}{d2g} \right]$$

$$f = 8 \left[\left(\frac{8}{Re} \right)^{12} + \left(\frac{1}{(A+B)^{1.5}} \right) \right]^{1/12}$$

$$A = \left[2.457 \ln \left(\frac{1}{(7/Re)^{0.9} + (0.27e/d)} \right) \right]^{16}$$

$$B = \left(\frac{37,530}{Re} \right)^{16}$$

Pressure Drop Charts

3/8" RadiantPEX+ / RadiantPERT, pressure drop per 100'											
°F	0.10 (0.32)	0.20 (0.65)	0.30 (0.97)	0.40 (1.29)	0.50 (1.61)	0.60 (1.94)	0.70 (2.26)	0.80 (2.58)	0.90 (2.90)	1.00 (3.23)	GPM (ft/sec)
80°	0.33	0.66	2.10	3.46	5.05	6.89	8.97	11.29	13.83	16.59	100% Water
	1.60	3.19	4.79	6.38	7.98	9.57	11.17	12.77	14.36	16.27	50% Water/Glycol
100°	0.26	0.82	1.98	3.23	4.73	6.46	8.42	10.61	13.01	15.63	100% Water
	1.09	2.18	3.28	4.37	5.46	6.55	7.94	12.32	18.25	23.29	50% Water/Glycol
120°	0.22	0.93	1.87	3.05	4.47	6.12	7.99	10.07	12.36	14.86	100% Water
	0.80	1.61	2.41	3.21	4.08	7.17	11.37	14.68	17.94	21.44	50% Water/Glycol
140°	0.18	0.89	1.77	2.90	4.26	5.84	7.63	9.63	11.83	14.23	100% Water
	0.62	1.24	1.86	2.60	5.53	8.31	10.83	13.57	16.57	19.82	50% Water/Glycol
160°	0.16	0.85	1.70	2.78	4.09	5.61	7.34	9.27	11.40	13.72	100% Water
	0.49	.099	1.49	3.54	5.71	7.79	10.11	12.69	15.51	18.57	50% Water/Glycol
180°	0.19	0.82	1.63	2.68	3.94	5.42	7.09	8.97	11.03	13.28	100% Water
	0.41	0.83	1.70	3.70	5.41	7.37	9.58	12.04	14.73	17.66	50% Water/Glycol

1/2" RadiantPEX+ / RadiantPERT, pressure drop per 100'															
°F	0.20 (0.36)	0.30 (0.53)	0.40 (0.71)	0.50 (0.89)	0.60 (1.07)	0.70 (1.24)	0.80 (1.42)	0.90 (1.60)	1.00 (1.78)	1.50 (2.67)	2.00 (3.55)	2.50 (4.44)	3.00 (5.33)	3.50 (6.22)	GPM (ft/sec)
80°	0.20	0.34	0.84	1.25	1.70	2.20	2.77	3.38	4.05	8.16	13.46	19.89	27.39	35.94	100% Water
	0.97	1.45	1.94	2.42	2.91	3.39	3.88	4.36	4.84	8.98	20.95	30.83	41.97	54.54	50% Water/Glycol
100°	0.16	0.46	0.80	1.16	1.58	2.06	2.59	3.17	3.81	7.69	12.72	18.82	25.96	34.11	100% Water
	0.66	0.99	1.33	1.66	1.99	2.32	2.65	3.01	3.83	11.55	18.80	27.48	37.52	48.89	50% Water/Glycol
120°	0.16	0.46	0.75	1.10	1.50	1.95	2.45	3.01	3.61	7.32	12.12	17.97	24.82	32.64	100% Water
	0.49	0.73	0.97	1.22	1.46	1.79	2.82	4.14	5.24	10.51	17.15	25.14	34.42	44.93	50% Water/Glycol
140°	0.20	0.44	0.71	1.04	1.42	1.86	2.34	2.87	3.45	7.01	11.64	17.27	23.88	31.43	100% Water
	0.38	0.56	0.75	0.94	1.51	2.52	3.33	4.09	4.89	9.73	15.93	23.40	32.10	41.97	50% Water/Glycol
160°	0.21	0.42	0.68	1.00	1.37	1.78	2.25	2.76	3.32	6.76	11.24	16.70	23.11	30.44	100% Water
	0.30	0.45	0.60	1.13	1.89	2.49	3.13	3.82	4.56	9.12	14.98	22.05	30.29	39.65	50% Water/Glycol
180°	0.20	0.40	0.65	0.96	1.32	1.72	2.17	2.67	3.21	6.55	10.90	16.21	22.45	29.59	100% Water
	0.25	0.38	0.67	1.31	1.82	2.36	2.96	3.62	4.33	8.68	14.28	21.05	28.95	37.94	50% Water/Glycol

5/8" RadiantPEX+ / RadiantPERT, pressure drop per 100'											
°F	0.50 (0.61)	1.00 (1.23)	1.50 (1.84)	2.00 (2.45)	2.50 (3.06)	3.00 (3.68)	3.50 (4.29)	4.00 (4.90)	4.50 (5.52)	5.00 (6.13)	GPM (ft/sec)
80°	0.52	1.69	3.39	5.57	8.22	11.31	14.82	18.75	23.08	27.80	100% Water
	1.15	2.30	3.46	7.46	12.84	17.55	22.78	28.57	34.91	41.80	50% Water/Glycol
100°	0.49	1.58	3.19	5.26	7.77	10.70	14.04	17.78	21.90	26.41	100% Water
	0.79	1.58	4.59	7.86	11.47	15.64	20.35	25.58	31.33	37.57	50% Water/Glycol
120°	0.46	1.50	3.03	5.00	7.41	10.21	13.42	17.00	20.96	25.29	100% Water
	0.58	1.85	4.40	7.16	10.47	14.31	18.65	23.49	28.81	34.59	50% Water/Glycol
140°	0.43	1.43	2.90	4.80	7.11	9.82	12.90	16.37	20.19	24.37	100% Water
	0.45	2.04	4.06	6.63	9.72	13.32	17.39	21.93	26.92	32.36	50% Water/Glycol
160°	0.42	1.37	2.79	4.63	6.86	9.49	12.48	15.84	19.55	23.62	100% Water
	0.36	1.91	3.80	6.22	9.14	12.54	16.40	20.71	25.45	30.61	50% Water/Glycol
180°	0.40	1.33	2.70	4.48	6.65	9.21	12.12	15.39	19.01	22.97	100% Water
	0.44	1.81	3.61	5.92	8.72	11.97	15.67	19.80	24.36	29.32	50% Water/Glycol

Pressure Drop Charts

3/4" RadiantPEX+ / RadiantPERT, pressure drop per 100'

°F	0.50 (0.45)	1.00 (0.90)	1.50 (1.35)	2.00 (1.80)	2.50 (2.25)	3.00 (2.70)	3.50 (3.15)	4.00 (3.61)	4.50 (4.06)	5.00 (4.51)	5.50 (4.96)	6.00 (5.41)	6.50 (5.86)	7.00 (6.31)	GPM (ft/sec)
80°	0.23	0.82	1.64	2.69	3.96	5.45	7.13	9.01	11.09	13.35	15.80	18.42	21.23	24.21	100% Water
	0.62	1.25	1.87	2.72	5.83	8.52	11.07	13.88	16.95	20.27	23.85	27.68	31.74	36.05	50% Water/Glycol
100°	0.24	0.77	1.54	2.53	3.74	5.15	6.75	8.54	10.51	12.66	14.99	17.50	20.18	23.02	100% Water
	0.43	0.85	1.76	3.81	5.58	7.59	9.87	12.39	15.17	18.17	21.41	24.88	28.57	32.49	50% Water/Glycol
120°	0.22	0.72	1.46	2.41	3.56	4.91	6.44	8.15	10.05	12.11	14.35	16.76	19.33	22.07	100% Water
	0.31	0.68	2.13	3.48	5.08	6.93	9.03	11.36	13.92	16.70	19.70	22.92	26.34	29.97	50% Water/Glycol
140°	0.21	0.69	1.40	2.31	3.42	4.71	6.19	7.84	9.67	11.66	13.82	16.15	18.64	21.28	100% Water
	0.24	0.95	1.97	3.21	4.71	6.44	8.40	10.58	12.99	15.60	18.42	21.44	24.66	28.08	50% Water/Glycol
160°	0.20	0.66	1.34	2.22	3.30	4.55	5.98	7.58	9.35	11.29	13.39	15.65	18.06	20.64	100% Water
	0.19	0.93	1.84	3.01	4.42	6.06	7.91	9.98	12.26	14.74	17.41	20.28	23.35	26.60	50% Water/Glycol
180°	0.19	0.64	1.30	2.15	3.19	4.41	5.80	7.36	9.08	10.97	13.01	15.22	17.57	20.08	100% Water
	0.17	0.88	1.75	2.86	4.21	5.78	7.55	9.54	11.72	14.10	16.67	19.43	22.37	25.50	50% Water/Glycol

1" RadiantPEX+ / RadiantPERT, pressure drop per 100'

°F	2.50 (1.36)	3.00 (1.64)	3.50 (1.91)	4.00 (2.18)	4.50 (2.46)	5.00 (2.73)	5.50 (3.00)	6.00 (3.28)	6.50 (3.55)	7.00 (3.82)	8.00 (4.37)	9.00 (4.91)	10.00 (5.46)	11.00 (6.01)	12.00 (6.55)	GPM (ft/sec)
80°	1.21	1.66	2.17	2.74	3.36	4.04	4.78	5.57	6.42	7.31	9.26	11.40	13.75	16.29	19.02	100% Water
	1.20	2.23	3.36	4.28	5.22	6.24	7.34	8.50	9.75	11.06	13.89	17.00	20.38	24.02	27.92	50% Water/Glycol
100°	1.14	1.56	2.05	2.29	3.18	3.83	4.53	5.28	6.08	6.94	8.79	10.84	13.08	15.51	18.11	100% Water
	1.71	2.34	3.04	3.81	4.66	5.57	6.56	7.61	8.74	9.92	12.50	15.32	18.39	21.71	25.26	50% Water/Glycol
120°	1.08	1.49	1.95	2.47	3.04	3.66	4.33	5.05	5.82	6.64	8.42	10.39	12.54	14.88	17.39	100% Water
	1.56	2.13	2.77	3.48	4.26	5.10	6.01	6.99	8.03	9.13	11.51	14.13	16.99	20.07	23.37	50% Water/Glycol
140°	1.04	1.43	1.87	2.37	2.92	3.51	4.16	4.86	5.60	6.39	8.11	10.02	12.10	14.36	16.79	100% Water
	1.45	1.97	2.57	3.23	3.96	4.75	5.61	6.52	7.50	8.53	10.77	13.24	15.93	18.83	21.95	50% Water/Glycol
160°	1.00	1.38	1.80	2.29	2.82	3.40	4.02	4.70	5.42	6.19	7.86	9.71	11.73	13.93	16.29	100% Water
	1.35	1.85	2.41	3.04	3.73	4.48	5.29	6.16	7.08	8.06	10.19	12.54	15.09	17.86	20.83	50% Water/Glycol
180°	0.97	1.33	1.75	2.22	2.73	3.30	3.91	4.56	5.27	6.01	7.64	9.44	11.42	13.56	15.87	100% Water
	1.29	1.76	2.30	2.90	3.56	4.28	5.06	5.89	6.78	7.72	9.76	12.02	14.48	17.14	20.00	50% Water/Glycol

Pressure Drop Charts

1-1/4" RadiantPEX+, pressure drop per 100'

°F	5.50 (2.01)	6.00 (2.19)	6.50 (2.38)	7.00 (2.56)	8.00 (2.93)	9.00 (3.29)	10.00 (3.66)	11.00 (4.02)	12.00 (4.39)	13.00 (4.76)	14.00 (4.96)	15.00 (5.12)	16.00 (5.85)	17.00 (6.22)	18.00 (6.58)	GPM (ft/sec)
80°	1.84	2.15	2.47	2.82	3.56	4.38	5.28	6.25	7.29	8.41	9.59	10.85	12.17	13.56	15.02	100% Water
	2.87	3.32	3.80	4.31	5.41	6.61	7.92	9.33	10.83	12.43	14.13	15.92	17.80	19.77	21.83	50% Water/Glycol
100°	1.74	2.03	2.34	2.67	3.38	4.16	5.02	5.94	6.94	8.00	9.13	10.33	11.59	12.92	14.32	100% Water
	2.55	2.96	3.40	3.86	4.85	5.94	7.13	8.40	9.77	11.23	12.78	14.41	16.12	17.92	19.81	50% Water/Glycol
120°	1.66	1.94	2.24	2.55	3.23	3.98	4.80	5.69	6.65	7.67	8.76	9.91	11.13	12.41	13.76	100% Water
	2.34	2.71	3.11	3.54	4.46	5.47	6.57	7.75	9.02	10.38	11.81	13.33	14.93	16.61	18.37	50% Water/Glycol
140°	1.60	1.86	2.15	2.45	3.11	3.83	4.63	5.49	6.41	7.40	8.45	9.57	10.75	11.99	13.29	100% Water
	2.17	2.53	2.90	3.30	4.16	5.11	6.14	7.26	8.46	9.73	11.09	12.52	14.03	15.62	17.28	50% Water/Glycol
160°	1.54	1.80	2.08	2.37	3.01	3.71	4.48	5.32	6.22	7.18	8.20	9.29	10.43	11.64	12.91	100% Water
	2.05	2.38	2.74	3.11	3.93	4.83	5.81	6.87	8.01	9.23	10.52	11.88	13.32	14.83	16.41	50% Water/Glycol
180°	1.50	1.75	2.02	2.30	2.92	3.61	4.36	5.17	6.05	6.98	7.98	9.04	10.16	11.34	12.58	100% Water
	1.95	2.27	2.61	2.98	3.76	4.63	5.57	6.59	7.68	8.85	10.09	11.41	12.79	14.25	15.77	50% Water/Glycol

1-1/2" RadiantPEX+, pressure drop per 100'

°F	7.00 (1.83)	8.00 (2.10)	9.00 (2.36)	10.00 (2.62)	11.00 (2.88)	12.00 (3.14)	13.00 (3.41)	14.00 (3.67)	15.00 (3.93)	16.00 (4.19)	17.00 (4.46)	18.00 (4.72)	19.00 (4.98)	20.00 (5.24)	25.00 (6.55)	GPM (ft/sec)
80°	1.27	1.61	1.98	2.38	2.82	3.29	3.79	4.32	4.88	5.48	6.10	6.75	7.44	8.15	12.14	100% Water
	1.97	2.47	3.02	3.61	4.25	4.93	5.66	6.43	7.24	8.09	8.98	9.91	10.89	11.90	17.53	50% Water/Glycol
100°	1.20	1.52	1.88	2.26	2.68	3.12	3.60	4.11	4.65	5.21	5.81	6.43	7.09	7.77	11.59	100% Water
	1.76	2.21	2.70	3.24	3.82	4.44	5.10	5.80	6.53	7.31	8.12	8.97	9.86	10.78	15.94	50% Water/Glycol
120°	1.15	1.46	1.79	2.16	2.56	2.99	3.45	3.94	4.45	5.00	5.57	6.17	6.80	7.46	11.14	100% Water
	1.61	2.03	2.48	2.98	3.51	4.09	4.70	5.35	6.03	6.76	7.51	8.30	9.13	9.99	14.80	50% Water/Glycol
140°	1.10	1.40	1.73	2.08	2.47	2.88	3.32	3.80	4.30	4.82	5.38	5.96	6.57	7.20	10.77	100% Water
	1.50	1.89	2.32	2.78	3.29	3.83	4.40	5.01	5.66	6.34	7.05	7.80	8.58	9.39	13.94	50% Water/Glycol
160°	1.07	1.35	1.67	2.01	2.39	2.79	3.22	3.68	4.16	4.68	5.21	5.78	6.37	6.99	10.46	100% Water
	1.41	1.78	2.19	2.63	3.11	3.62	4.17	4.75	5.36	6.01	6.69	7.40	8.14	8.92	13.25	50% Water/Glycol
180°	1.04	1.31	1.62	1.96	2.32	2.71	3.13	3.58	4.05	4.55	5.08	5.63	6.21	6.81	10.20	100% Water
	1.35	1.70	2.09	2.52	2.98	3.47	3.99	4.55	5.14	5.77	6.42	7.10	7.82	8.57	12.74	50% Water/Glycol

2" RadiantPEX+, pressure drop per 100'

°F	11.00 (1.68)	12.00 (1.84)	13.00 (1.99)	14.00 (2.14)	15.00 (2.29)	16.00 (2.45)	17.00 (2.60)	18.00 (2.75)	19.00 (2.91)	20.00 (3.06)	25.00 (3.82)	30.00 (4.59)	35.00 (5.35)	40.00 (6.12)	45.00 (6.88)	GPM (ft/sec)
80°	0.78	0.91	1.05	1.20	1.35	1.51	1.69	1.87	2.05	2.25	3.34	4.63	6.10	7.75	9.58	100% Water
	1.20	1.39	1.59	1.81	2.03	2.27	2.52	2.78	3.05	3.33	4.90	6.72	8.79	11.10	13.64	50% Water/Glycol
100°	0.74	0.86	1.00	1.13	1.28	1.44	1.60	1.77	1.95	2.14	3.19	4.41	5.82	7.40	9.15	100% Water
	1.07	1.24	1.43	1.62	1.83	2.04	2.27	2.51	2.75	3.01	4.44	6.10	8.00	10.11	12.44	50% Water/Glycol
120°	0.71	0.83	0.95	1.09	1.23	1.38	1.53	1.70	1.87	2.05	3.06	4.24	5.60	7.12	8.81	100% Water
	0.98	1.14	1.31	1.49	1.68	1.88	2.09	2.31	2.54	2.78	4.11	5.66	7.43	9.41	11.59	50% Water/Glycol
140°	0.68	0.79	0.92	1.05	1.18	1.33	1.48	1.64	1.80	1.98	2.95	4.10	5.41	6.89	8.53	100% Water
	0.92	1.07	1.23	1.40	1.57	1.76	1.96	2.17	2.38	2.61	3.86	5.33	7.00	8.87	10.94	50% Water/Glycol
160°	0.66	0.77	0.89	1.01	1.14	1.28	1.43	1.59	1.75	1.92	2.86	3.98	5.26	6.69	8.29	100% Water
	0.87	1.01	1.16	1.32	1.49	1.67	1.85	2.05	2.26	2.47	3.66	5.06	6.65	8.44	10.42	50% Water/Glycol
180°	0.64	0.75	0.86	0.98	1.11	1.25	1.39	1.54	1.70	1.86	2.79	3.87	5.12	6.53	8.09	100% Water
	0.83	0.96	1.11	1.26	1.43	1.60	1.78	1.97	2.16	2.37	3.52	4.86	6.40	8.13	10.03	50% Water/Glycol

Pressure Drop Charts

3/8" RadiantPEX-AL, pressure drop per 100'

°F	0.10 (0.35)	0.20 (0.70)	0.30 (1.05)	0.40 (1.40)	0.50 (1.75)	0.60 (2.10)	0.70 (2.44)	0.80 (2.79)	0.90 (3.14)	1.00 (3.49)	GPM (ft/sec)
80°	0.39	0.79	2.55	4.17	6.09	8.31	10.82	13.62	16.69	20.02	100% Water
	1.87	3.74	5.61	7.48	9.35	11.22	13.09	14.96	16.86	19.87	50% Water/Glycol
100°	0.31	1.05	2.39	3.89	5.70	7.79	10.16	12.80	15.71	18.87	100% Water
	1.28	2.56	3.84	5.12	6.40	7.68	9.91	16.02	22.78	28.25	50% Water/Glycol
120°	0.25	1.13	2.25	3.67	5.39	7.38	9.64	12.16	14.93	17.95	100% Water
	0.94	1.88	2.82	3.76	4.95	9.29	13.92	17.70	21.62	25.83	50% Water/Glycol
140°	0.21	1.07	2.14	3.15	5.14	7.05	9.21	11.63	14.29	17.19	100% Water
	0.73	1.45	2.18	3.27	6.96	10.04	13.04	16.35	19.97	23.89	50% Water/Glycol
160°	0.20	1.03	2.05	3.35	4.93	6.77	8.87	11.20	13.77	16.58	100% Water
	0.58	1.16	1.78	4.46	6.89	9.38	12.18	15.29	18.70	22.39	50% Water/Glycol
180°	0.25	0.98	1.97	3.23	4.76	6.54	8.57	10.83	13.33	16.05	100% Water
	0.49	0.97	2.22	4.46	6.52	8.88	11.55	14.52	17.77	21.30	50% Water/Glycol

1/2" RadiantPEX-AL, pressure drop per 100'

°F	0.20 (0.33)	0.30 (0.50)	0.40 (0.67)	0.50 (0.84)	0.60 (1.00)	0.70 (1.17)	0.80 (1.34)	0.90 (1.50)	1.00 (1.67)	1.50 (2.51)	2.00 (3.34)	2.50 (4.18)	3.00 (5.02)	3.50 (5.85)	GPM (ft/sec)
80°	0.18	0.28	0.72	1.08	1.47	1.91	2.40	2.93	3.51	7.06	11.65	17.20	23.69	31.08	100% Water
	0.86	1.29	1.72	2.14	2.57	3.00	3.43	3.86	4.29	7.36	18.02	26.72	36.37	47.26	50% Water/Glycol
100°	0.14	0.39	0.69	1.01	1.37	1.79	2.24	2.75	3.30	6.65	11.00	16.28	22.45	29.48	100% Water
	0.29	0.88	1.17	1.47	1.76	2.05	2.35	2.65	3.18	10.00	16.30	23.81	32.50	42.34	50% Water/Glycol
120°	0.13	0.40	0.65	0.95	1.30	1.69	2.12	2.60	3.13	6.33	10.48	15.54	21.45	28.21	100% Water
	0.43	0.65	0.86	1.08	1.29	1.54	2.30	3.47	4.50	9.11	14.86	21.77	29.80	38.89	50% Water/Glycol
140°	0.17	0.38	0.62	0.90	1.23	1.61	2.03	2.49	2.99	6.06	10.06	14.93	20.64	27.16	100% Water
	0.33	0.50	0.67	0.83	1.23	2.11	2.88	3.54	4.24	8.43	13.79	20.26	27.78	36.32	50% Water/Glycol
160°	0.18	0.36	0.59	0.86	1.18	1.54	1.95	2.39	2.87	5.85	9.71	14.43	19.97	26.29	100% Water
	0.27	0.40	0.53	0.92	1.62	2.16	2.71	3.31	3.95	7.90	12.97	19.08	26.21	34.30	50% Water/Glycol
180°	0.17	0.35	0.57	0.83	1.14	1.49	1.88	2.31	2.78	5.66	9.42	14.00	19.39	25.56	100% Water
	0.22	0.33	0.55	1.12	1.58	2.05	2.56	3.13	3.75	7.51	12.36	18.22	25.05	32.82	50% Water/Glycol

5/8" RadiantPEX-AL, pressure drop per 100'

°F	0.50 (0.52)	1.00 (1.03)	1.50 (1.55)	2.00 (2.06)	2.50 (2.58)	3.00 (3.09)	3.50 (3.61)	4.00 (4.12)	4.50 (4.64)	5.00 (5.15)	GPM (ft/sec)
80°	0.33	1.12	2.25	3.69	5.44	7.48	9.80	12.39	15.25	18.36	100% Water
	0.81	1.63	2.44	4.19	8.37	11.67	15.15	18.99	23.20	27.76	50% Water/Glycol
100°	0.32	1.05	2.11	3.48	5.14	7.07	9.28	11.74	14.46	17.43	100% Water
	0.56	1.11	2.73	5.23	7.63	10.39	13.51	16.98	20.78	24.91	50% Water/Glycol
120°	0.30	0.99	2.00	3.31	4.90	6.75	8.86	11.22	13.83	16.68	100% Water
	0.41	1.04	2.92	4.76	6.95	9.50	12.37	15.58	19.09	22.92	50% Water/Glycol
140°	0.29	0.95	1.92	3.17	4.70	6.48	8.52	10.79	13.31	16.06	100% Water
	0.32	1.34	2.70	4.40	6.45	8.83	11.52	14.53	17.83	21.42	50% Water/Glycol
160°	0.28	0.91	1.85	3.06	4.53	6.26	8.23	10.44	12.88	15.56	100% Water
	0.25	1.27	2.52	4.13	6.06	8.31	10.86	13.71	16.84	20.24	50% Water/Glycol
180°	0.27	0.88	1.78	2.96	4.39	6.07	7.99	10.14	12.52	15.12	100% Water
	0.25	1.20	2.40	3.93	5.78	7.93	10.37	13.10	16.10	19.38	50% Water/Glycol

Pressure Drop Charts

3/4" RadiantPEX-AL, pressure drop per 100'

°F	0.50 (0.32)	1.00 (0.64)	1.50 (0.97)	2.00 (1.29)	2.50 (1.61)	3.00 (1.93)	3.50 (2.25)	4.00 (2.57)	4.50 (2.90)	5.00 (3.22)	5.50 (43.54)	6.00 (3.86)	6.50 (4.18)	7.00 (4.50)	GPM (ft/sec)
80°	0.08	0.37	0.74	1.21	1.78	2.45	3.20	4.04	4.97	5.98	7.07	8.24	9.49	10.82	100% Water
	0.32	0.64	0.95	1.27	1.98	3.65	5.01	6.29	7.68	9.18	10.79	12.51	14.35	16.28	50% Water/Glycol
100°	0.10	0.35	0.69	1.14	1.68	2.31	3.02	3.82	4.70	5.66	6.70	7.82	9.01	10.28	100% Water
	0.22	0.43	0.66	1.59	2.53	3.44	4.47	5.61	6.85	8.21	9.66	11.22	12.88	14.63	50% Water/Glycol
120°	0.10	0.33	0.66	1.08	1.60	2.20	2.88	3.65	4.49	5.41	6.41	7.48	8.62	9.84	100% Water
	0.16	0.32	0.91	1.58	2.30	3.13	4.08	5.13	6.28	7.52	8.87	10.31	11.85	13.47	50% Water/Glycol
140°	0.10	0.31	0.63	1.04	1.53	2.11	2.77	3.50	4.32	5.20	6.16	7.20	8.30	9.48	100% Water
	0.12	0.33	0.89	1.46	2.13	2.91	3.79	4.77	5.84	7.01	8.28	9.63	11.07	12.60	50% Water/Glycol
160°	0.09	0.30	0.60	1.00	1.48	2.03	2.67	3.38	4.17	5.03	5.96	6.97	8.04	9.18	100% Water
	0.10	0.41	0.83	1.36	1.99	2.73	3.56	4.49	5.51	6.62	7.81	9.10	10.47	11.92	50% Water/Glycol
180°	0.09	0.29	0.58	0.96	1.43	1.97	2.59	3.28	4.05	4.89	5.79	6.77	7.81	8.92	100% Water
	0.08	0.40	0.79	1.29	1.90	2.60	3.40	4.28	5.26	6.32	7.47	8.70	10.02	11.41	50% Water/Glycol

1" RadiantPEX-AL, pressure drop per 100'

°F	2.50 (0.98)	3.00 (1.18)	3.50 (1.37)	4.00 (1.57)	4.50 (1.77)	5.00 (1.96)	5.50 (2.16)	6.00 (2.36)	6.50 (2.55)	7.00 (2.75)	8.00 (3.14)	9.00 (3.53)	10.00 (3.93)	11.00 (4.32)	12.00 (4.71)	GPM (ft/sec)
80°	0.55	0.76	0.99	1.25	1.54	1.85	2.18	2.54	2.92	3.33	4.21	5.19	6.25	7.40	8.63	100% Water
	0.59	0.76	1.31	1.92	2.40	2.88	3.38	3.92	4.49	5.09	6.39	7.81	9.35	11.02	12.79	50% Water/Glycol
100°	0.52	0.71	0.93	1.18	1.45	1.74	2.06	2.40	2.77	3.16	4.00	4.92	5.94	7.03	8.21	100% Water
	0.71	1.07	1.40	1.76	2.14	2.56	3.01	3.50	4.01	4.55	5.73	7.02	8.42	9.93	11.55	50% Water/Glycol
120°	0.49	0.68	0.89	1.12	1.38	1.66	1.97	2.30	2.64	3.02	3.82	4.71	5.69	6.74	7.87	100% Water
	0.72	0.98	1.27	1.60	1.96	2.34	2.76	3.20	3.68	4.18	5.27	6.46	7.76	9.16	10.67	50% Water/Glycol
140°	0.47	0.65	0.85	1.08	1.33	1.60	1.89	2.21	2.54	2.90	3.68	4.54	5.48	6.50	7.59	100% Water
	0.67	0.91	1.18	1.48	1.82	2.18	2.57	2.98	3.43	3.90	4.92	6.04	7.26	8.58	10.00	50% Water/Glycol
160°	0.46	0.63	0.82	1.04	1.28	1.54	1.83	2.13	2.46	2.81	3.56	4.39	5.31	6.30	7.36	100% Water
	0.62	0.85	1.11	1.39	1.71	2.05	2.42	2.81	3.23	3.68	4.65	5.71	6.88	8.13	9.48	50% Water/Glycol
180°	0.44	0.61	0.80	1.01	1.24	1.50	1.77	2.07	2.39	2.72	3.46	4.27	5.16	6.13	7.16	100% Water
	0.59	0.81	1.05	1.33	1.63	1.96	2.31	2.69	3.09	3.52	4.45	5.47	6.59	7.79	9.09	50% Water/Glycol



WATTS®