

- **Up to 1380 lbs. of force**
- **Excellent range control**
- **Accurate repetitive positioning**
- **Dual NAMUR Accessory Mounts**
- **Field Reversible**
- **“Long-life” design lasts over one million cycles**

TABLE OF CONTENTS

Features2
 Description3
 Guide to Applications3
 Operation3
 Installing an Actuator4
 Changing Springs4-5
 Changing Action6-7
 Preload8
 Replacing a Diaphragm9-10
 Parts List11-13
 Spring Range Matrix13
 Modification Data Table14-16

FLOWRITE II

46” Actuator



Powers’ most popular actuator is powerful, durable, and versatile.

POWERS

A WATTS INDUSTRIES CO.

FEATURES

1. Optional stainless steel springs extend operating life to over one million cycles.
2. Nested spring design creates a uniform stroke by eliminating spring side flex.
3. 316 Stainless steel thrust plate is corrosion resistant.
4. All stainless steel hardware used in combination with SS spring makes long-life standard.
5. Molded fiber and reinforced diaphragm greatly reduces the risk of stress cracks.
6. Rolling diaphragm design allows for even pressure during the stroke cycle making for more precise control.
7. Field reversible design makes changing the fail-safe mode possible.
8. With *extended nut hardware, preload can be safely released for inspection.
9. Dual NAMUR mounts can be used to quickly add or reorient accessories.

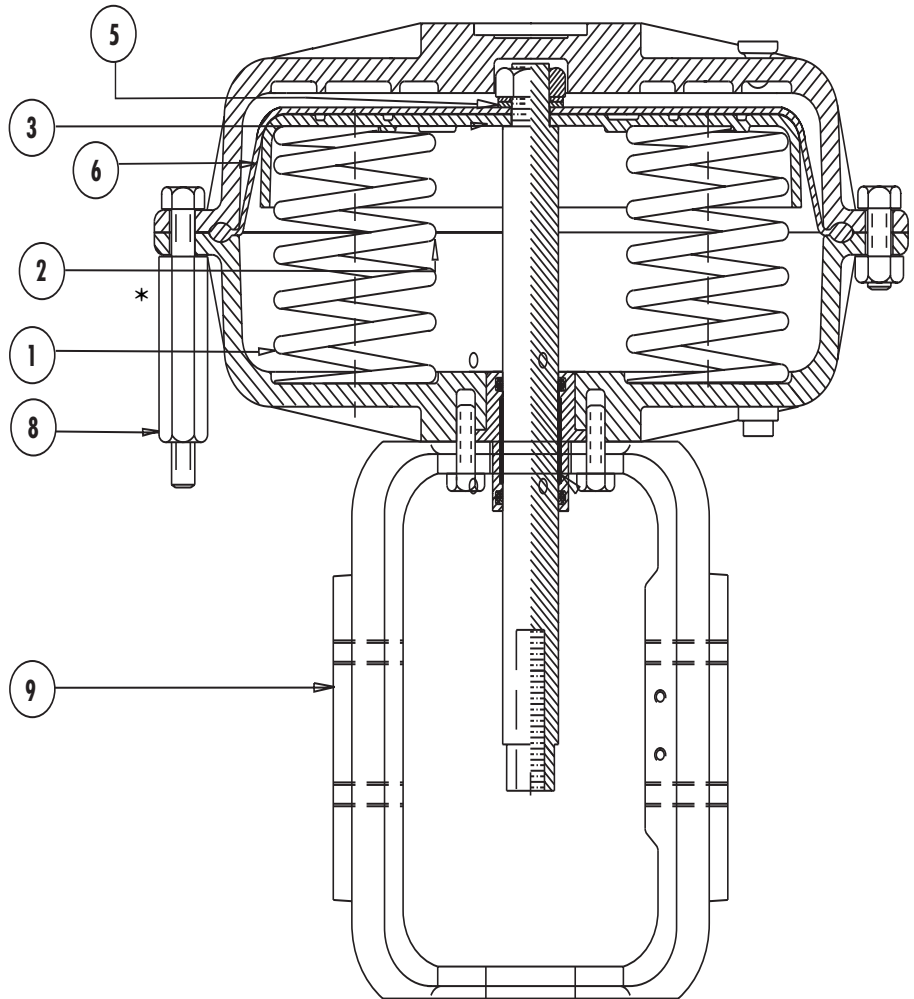

DESCRIPTION

Powers' most popular actuator, the '46', is a versatile, field reversible design that is available on most Flowrite II valves. This actuator provides:

- large effective area (1380 lbs of force at 30 psi) for powerful valve close control
- excellent narrow range control signal performance
- accurate repetitive positioning due to large diameter diaphragm, low friction actuator stem and bronze bearings, and
- dual NAMUR accessory mounts.

The 46 actuator and Flowrite II valves are designed to integrate into a highly flexible system. It is possible through the Flowrite II 46" actuation system to adapt to changing application requirements by reconfiguring the actuator through simple spring changes, stem changes, etc. The purpose of these instructions is to suggest solutions to meet your applications needs.

OPERATION

The actuator springs provide the necessary force to hold the stem in the lowered or raised position.

On a Normally Open valve (ATC, D/A) assembly, the stem will start its downward stroke whenever the control air pressure applied against the actuator diaphragm area and upper housing exceeds the holding force of the springs.

A further increase in control air pressure will initiate a continued downward travel of the valve stem until the valve has completed its stroke.

On a Normally Closed valve (ATO) assembly, the valve stem will start its upward stroke whenever the control air pressure applied against the actuator diaphragm area and the lower housing exceeds the holding force of the springs.

A further increase in control air pressure will initiate a continued upward travel of the valve stem until the valve has completed its stroke.

The air pressure change to initiate full stem travel is known as the throttling range or spring span. Standard spring span is equal to 8 psi (55 kPa) with no drop across the valve.

This throttling range is based on typical system pressure and will vary slightly as the pressure drop across the valve changes. A decrease in pressure at the diaphragm will initiate an upward movement on a normally open valve assembly and a downward movement on a normally closed valve assembly.

When the valve is at its wide open position, the disc and throttling plug are farthest from the seat and there is maximum flow through the valve.

Valve actuators equipped with a pilot positioner can utilize full control air pressure at any point in the stem travel to initiate stem movement or to maintain stem position.

However, the actuator springs still provide the necessary force to move the stem in the opposite direction.

Use of a positioner will tend to provide faster response and to ensure repeatability of stem position regardless of the load on the actuator.

However, in a system where available pressure and flow requirements are relatively consistent, control valves can usually perform adequately without a positioner.

GUIDE TO APPLICATIONS

To reverse actuator action, i.e., change an NO to an NC valve, or an NC to an NO valve:

1. Refer to the Modification Tables for correct replacement parts.
2. Follow instructions for Reversing Actuator Action.
3. Follow instructions for Preload Adjustment.

To attempt valve sequencing with a 3-15 psi air signal OR to set a NC valve assembly at a higher preload to maintain closeoff or to increase the throttling range:

1. Refer to the Modification Tables for correct replacement parts.
2. Refer to Changing Springs.
3. Follow instructions for Preload Adjustment.
4. Use dimensions in the Spring Range Matrix.

To modify the actuator action, i.e., using the same actuator on a different valve body or size:

1. Refer to Modification Tables for correct replacement parts.
2. Refer to Changing Springs.

3. Refer to Changing Action (changing stems).

4. Follow instructions for Preload Adjustment.

5. Use dimensions in the Spring Range Matrix.

To install an actuator on a valve and set the preload adjustment:

1. Follow Installing Actuator instructions.
2. Refer to Modification Tables for correct replacement parts.
3. Follow instructions in Preload Adjustment.

To replace a ruptured diaphragm:

1. Refer to Replacing the Diaphragm instructions.

INSTALLING AN ACTUATOR

1. Place actuator assembly over valve stem. With actuator stem and valve stem separated, place bonnet lock nut over valve stem onto bonnet.
2. Apply air pressure to the actuator approximately 9 psi for a Normally Closed valve assembly, and 3 psi for a Normally Open Assembly.
3. Tighten the valve stem to the actuator stem by rotating the valve stem (NOT THE ACTUATOR STEM).
4. Tighten the two locknuts together and rotate them clockwise. Tighten the nuts to achieve the proper PRELOAD (as explained in the Preload Section).

5. Remove air pressure.
6. Tighten the bonnet locknut on the bonnet (Fig.1).



Fig 1 - Tighten the Bonnet Lock Nut on the Bonnet

CHANGING SPRINGS (DIRECT ACTING ACTUATORS)

Springs can be changed or added if a higher shutoff rating is required. This may become necessary under the following conditions:

1. If the pressure of the medium passing through the valve increases,
2. If the valve size increases due to an increase in process demand, or
3. If valve body type is changed.

The Modification Data Tables (page 13-15) provide dimensional data including part numbers, and number of springs required to reconfigure an actuator.

Springs may be changed with the actuator assembled or removed from the valve. For ease of instruction, pictures are shown with actuators removed.

To change or add springs on a Direct Acting (DA, NO, ATC) actuator assembled to the valve, follow steps 1, 2, 3, 4A, 5-10.

To change or add springs on a Direct Acting (DA, NO, ATC) actuator removed to the bench, follow steps: 1-4A, 5-9.

To change or add springs on a Direct Acting (DA, NO, ATC) actuator assembled to the valve and under preload, follow steps: 1, 3, 4B, 5-10.

1. Shut off controlled medium supply (steam, water, or other liquid).
 2. Reduce preload on the springs (refer to Decreasing Preload on DA Actuators pg. 7).
 3. Remove the control signal to the actuator.
 - 4A. (Fig. 1) Remove top housing nuts and bolts or (see above)
 - 4B. (Fig. 1) Remove the three bolts attached to the short nuts, then equally release the bolts attached to the long nuts.
- CAUTION: Springs under tension.**
5. (Fig. 2A) Remove upper housing.
 6. Remove stem nut, silver and black washers (Fig. 2B).
 7. Remove diaphragm, and thrust plate (Fig. 2C).
 8. Change or add springs as needed (Fig. 3A & 3B). Make sure the springs are properly placed over the spring guides and their configuration is symmetrical.
 9. Reassemble parts in reverse order, then attach upper housing.
 10. Adjust preload ref.

NOTE: Some actuator models have small springs nested inside the larger springs. The small springs also fit over spring guides and must also be placed symmetrically.



Fig 1 - Remove Housing Bolts
*(extended versions last and gradually)



Fig 2A - Remove Upper Housing



Fig 2B - Remove Stem Nut, & Washers

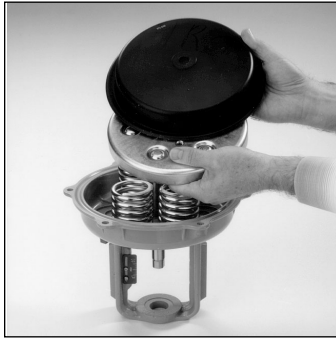

Fig 2C - Remove Diaphragm, Thrust Plate

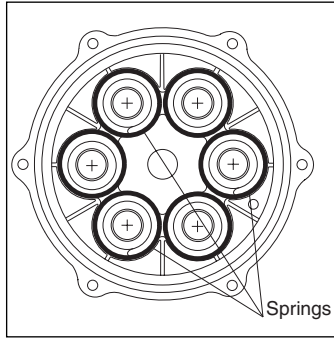

Fig 3A - Typical-Spring Installation

CHANGING SPRINGS (REVERSE ACTING ACTUATORS)

Springs may be changed with the actuator assembled or removed from the valve. For ease of instruction, pictures are shown with actuators removed.

To change or add springs on a Reverse Acting (RA, NC, ATO) actuator assembled to the valve, follow steps 1-4A, 5-8.

To change or add springs on a Reverse Acting (RA, NC, ATO) actuator removed to the bench, follow steps: 1-4A, 5-7.

To change or add springs on a Reverse Acting (RA, NC, ATO) actuator assembled to the valve and under preload, follow steps: 1, 3, 4B, 5-8.

1. Shut off controlled medium supply (steam, water, or other liquid).

2. Reduce preload on the springs (refer to Decreasing Preload on DA Actuators pg. 7).
3. Remove the control signal to the actuator.
- 4A. (Fig. 1) Remove top housing nuts and bolts or (see above).
- 4B. (Fig. 1) Remove the three bolts attached to the short nuts, then equally release the bolts attached to the long nuts.

CAUTION: Springs under tension.

5. (Fig. 2A) Remove upper housing.
6. Add or remove springs as needed for new configuration (Fig 3A & Fig. 3B). Make sure the springs are properly placed over the spring guides and their configuration is symmetrical.

NOTE: Some actuator models have small springs nested inside the larger springs. The small springs also fit over spring guides and must also be placed symmetrically.
7. Reassemble upper housing.

NOTE: Assemble bolts with long nuts first.
8. Adjust preload ref pg. 7.



Fig 1 - Remove Housing Bolts



Fig 2 - Remove Upper Housing

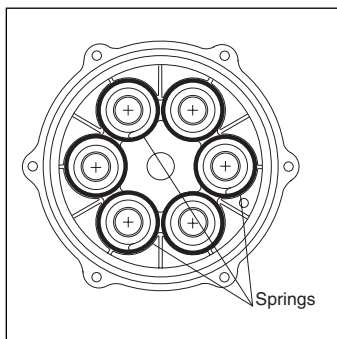

Fig 3A - Typical 3-Spring Installation

NOTE: *Number required may vary. Refer to page 14-15.

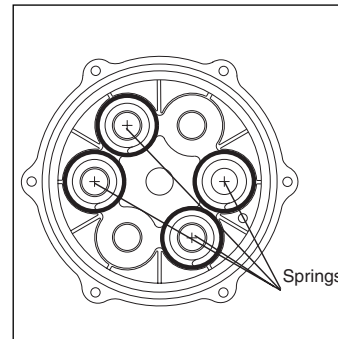

Fig 3A - Typical 4-Spring Installation

CHANGING ACTION (DIRECT ACTING ACTUATORS)

All valve bodies used with Flowrite II Actuators are push-to-close. Directing Acting actuators make the valve action Normally Open (NO, DA, ATC); Reverse Acting actuators make the valve action Normally Closed (NC, RA, ATO).

Changing the action of the actuator (DA to RA or RA to DA) will therefore reverse the valve action from NO to NC, or NC to NO. To change the actuator action, you change the stem and reverse the order of the spring, diaphragm and thrust plate assembly.

Change Actuator Action from DA to RA or NO to ATC or NC to ATO:

1. Shut off controlled medium supply (steam, water, or other liquid).
2. Reduce preload on the springs (refer to Decreasing Preload on DA Actuators).
3. Remove the control signal to the actuator.
4. Remove top housing nuts and bolts.
5. Remove upper housing. Remove stem nut, silver and black washer. (Fig 2A).
6. Remove diaphragm, thrust plate and springs (Fig. 2B).
7. Hold the actuator stem in place and loosen the valve stem locknuts (turn locknuts counterclockwise a number of times).

8. Hold actuator stem and tighten the two lock nuts together. Turn the locknuts counterclockwise to rotate the valve stem until the two stems are separated. (Fig. 3)
9. Pull actuator stem upward and remove from assembly (Fig. 4).
10. Replace with RA actuator stem. Position stem with flats pointing downward.
11. Thread valve stem into actuator stem by turning the locknuts clockwise. Tighten by hand.
12. Place black washer on actuator stem. Invert diaphragm and place inside of lower housing over the black washer. Invert thrust plate and place on top of diaphragm. (Fig. 5)
13. Replace silver washer and tighten stem nut.
14. Place springs on thrust plate in same orientation as found in lower housing. Properly seat springs over spring guides (Fig. 6).
15. Replace upper housing assembly and tighten housing nuts and bolts. (Fig. 1)
16. Connect control signal to 1/4" NPT fitting located on bottom of actuator housing.
17. Adjust the preload per instructions on pg. 7.



Fig 1 - Remove Housing Bolts



Fig 2A - Remove Upper Housing, Stem, Nut and Washers

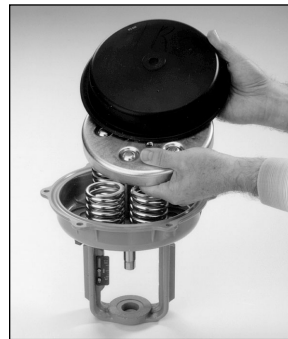

Fig 2B - Remove Diaphragm and Thrust Plate



Fig 3 - Loosen Stem Locknuts

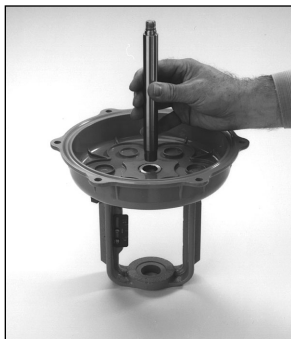

Fig 4 - Remove Stem

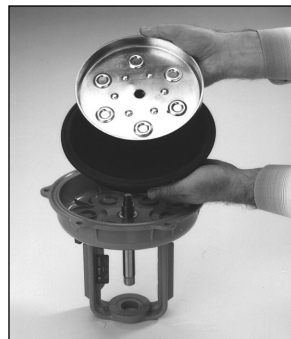

Fig 5 - Reverse Replacement of Diaphragm and Thrust Plate



Fig 5 - Reverse Replacement of Diaphragm and Thrust Plate. Four (4) springs shown. See note on page 5.

CHANGING ACTION (REVERSE ACTING ACTUATORS)

Change Actuator Action from RA to DA:

1. Shut off controlled medium supply (steam, water, or other liquid).
2. Reduce preload on the springs (refer to **Decreasing Preload on RA Actuators**).
3. Remove the control signal to the actuator.
4. (Fig. 1) Use a 1/2" wrench on the top housing bolts and hold the bottom housing nuts with a 9/16" wrench.
5. (Fig. 2A) Remove upper housing.
6. Remember the orientation of springs on the thrust plate. Remove springs, stem nut (Fig. 2B)...
7. ...silver washer, thrust plate, diaphragm, & black washer (Fig. 2C).
8. Hold the actuator stem in place and loosen the valve stem locknuts (turn locknut counterclockwise a number of times).
9. Hold actuator stem and tighten the two lock nuts together. Turn the locknuts counterclockwise to rotate the valve stem until the two stems are separated. (Fig. 3)
10. Pull actuator stem upward and remove from assembly. (Fig. 4).
11. Replace with DA actuator stem. Position stem with flats pointing downward.
12. Thread valve stem into actuator stem by turning the locknut clockwise. Tighten by hand.
13. Place springs in lower housing in same orientation as found on thrust plate. Properly seat springs over the spring guides
14. Invert thrust plate and place on top of springs. Invert diaphragm and place on top of thrust plate (Fig. 5).
15. Replace black washer, place silver washer on top of black washer, and tighten stem nut (Fig. 6).
16. Replace upper housing assembly and tighten housing nuts and bolts (Fig. 1).
17. Connect control signal to 1/4" NPT fitting located on the top of the actuator housing.
18. Adjust the preload per instructions on pg. 7.



Fig 1 - Remove Housing Bolts



Fig 2A - Remove Upper Housing to Expose Springs (4 Shown)



Fig 2B - Remove Springs, Stem Nut



Fig 2C - Remove Washers, Thrust Plate, Diaphragm

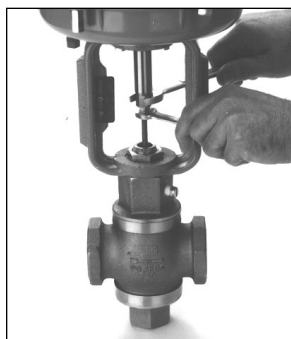

Fig 3 - Loosen Stem Locknuts

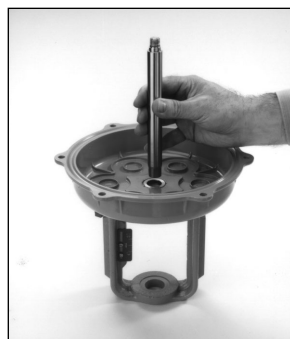

Fig 4 - Remove and Replace Stem



Fig 5 - Replace Springs, Reversed Thrust Plate and Diaphragm



Fig 6 - Replace Washers, Tighten Stem Nut

PRELOAD

The Normally Closed (NC, RC, ATO) valve assembly uses the springs to hold the valve shut, against the upstream pressure attempting to push the plug open.

1. All Normally Closed valve assemblies are factory set to a nominal preload depending on size of 7-10 psi.
2. If your process requires a high air pressure signal (>7 psi) to start the valve moving, it is necessary to decrease the actuator preload. Adjust the preload so that the valve is fully closed with the minimum air signal and fully open with the maximum air signal.
3. It is a characteristic of an unbalanced valve that as the pressure drop across the valve increases, the effective spring range increases. Consult one of our application engineers if you have any questions about your particular application.

The Normally Open (NO, DA, ATC) valve assembly uses the actuator springs to hold the valve open, and the upstream pressure helps to hold the valve open.

1. If the maximum air signal applied to the valve does not allow the valve to shut off tightly, decrease the preload.
2. If the valve starts closing at too low of an air signal, increase the preload. The preload should be adjusted so that control air pressure closes the valve tightly, and stem movement starts at an acceptable point.
3. In some applications where a wide range of flow conditions are encountered, it is desirable to install two valves in parallel and sequence them.

Preload adjustment (also called spring tension adjustment) is required under the following conditions:

1. The valve and actuator stem have been disengaged. (for packing changes, stem changes, maintenance of valve assembly, etc.)
2. The action of the valve assembly has been reversed.
3. Valve sequencing is required. (Use of a positioner is recommended if using a 3–15 psi control signal.)
4. Line pressure force exceeds the spring holding force on a normally closed (NC) valve assembly, which causes the valve to open with less than 7 psi signal preload.
5. Line pressure force adds to the spring holding force on a normally open (NO) valve assembly, which causes the valve to start closing at a preload greater than 3 psi signal

Deviation from this recommended preload setting will affect your process. A higher preload setting requires a higher air signal at the diaphragm to start stroking the valve. If the preload is too high, with a given air signal a Normally Open valve will not close completely, and a Normally Closed valve will not open completely to overcome the initial preload setting.

To decrease preload on RA actuators or increase preload on DA actuators:

1. To prevent the plug and seat from scoring, lift the valve plug off the seat before adjusting the preload by applying air pressure to the actuator, approximately 9 psi for a Normally Closed valve assembly, and 5 psi for a Normally Open Assembly.
2. Hold the actuator stem in place (DO NOT turn actuator stem during this process) and loosen the valve stem locknut by turning the locknuts counterclockwise a number of times. Press the two locknuts together.
3. Hold the actuator stem in place (DO NOT turn the actuator stem), turn the valve stem clockwise and retighten the locknut. (Fig. 1).

To increase preload on R.A. actuators or decrease preload on D.A. actuators:

1. To prevent the plug and seat from scoring, lift the valve plug off the seat before adjusting the preload by applying air pressure to the actuator, approximately 10 psi for a Normally Closed valve assembly, and 5 psi for a Normally Open Assembly.
2. Hold the actuator stem in place (DO NOT turn actuator stem during this process) and loosen the valve stem locknuts by turning the locknuts counterclockwise a number of times. Press the two locknuts together.
3. Hold the actuator stem in place (DO NOT turn the actuator stem), turn the valve stem locknuts counter-clockwise and retighten the locknut (Fig. 1).

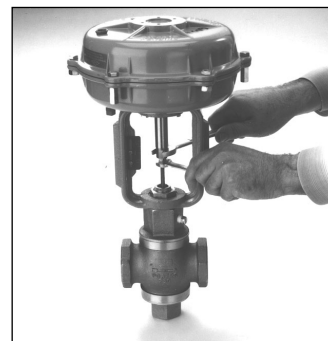

Fig 1 - Rotate Lock Nuts to Adjust Preload

REPLACING A DIAPHRAGM (DIRECT ACTING ACTUATORS)

The diaphragm can be changed with the actuator assembled or removed from the valve. For ease of instruction pictures are shown with actuators removed.

To change a diaphragm on a Direct Acting (DA, NO, ATC) actuator assemble to the valve follow steps: 1-4A, 5-9.

To change a diaphragm on a Direct Acting (DA, NO, ATC) actuator removed to the bench follow steps: 1-4A, 5-8.

To change a diaphragm of a Direct Acting (DA, NO, ATC) actuator assemble to the valve and under preload follow steps: 1-3, 4B, 5-9.

1. Shut off controlled medium supply (steam, water, or other liquid) and remove the control signal to the actuator.
2. Reduce preload on the springs (refer to Decreasing Preload on DA Actuators), see pg. 7.
3. Remove the control signal from the actuator.
- 4A. (Fig. 1) Remove top housing nuts and bolts or (see above)
- 4B. (Fig. 1) Remove the three bolts attached to the short nuts, then equally release the bolts attached to the long nuts.

CAUTION: Springs under tension.

5. Remove upper housing (Fig. 2)
6. Remove stem nut, washer and diaphragm. (Fig. 3)
7. Place new diaphragm over thrust plate. Make sure that the lip of the diaphragm is seated properly in the groove of the actuator housing.
8. Reassemble in reverse order.
9. Adjust preload, refer to pg. 7.



Fig 1 - Remove Housing Bolts



Fig 2 - Remove Stem Nut, and Washers

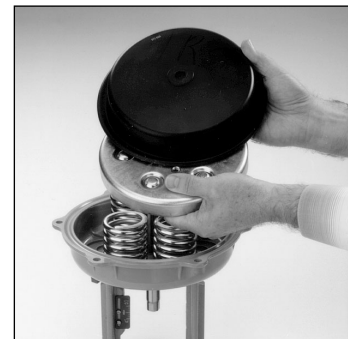

Fig 3 - Remove Diaphragm (Leave Thrust Plate On).

REPLACING A DIAPHRAGM (REVERSE ACTING ACTUATORS)

The diaphragm can be changed with the actuator assembled or removed from the valve. For ease of instruction pictures are shown with actuators removed.

To change a diaphragm on a Reverse Acting (RA, NC, ATO) actuator assemble to the valve follow steps: 1-4A, 5-10.

To change a diaphragm on a Reverse Acting (RA, NC, ATO) actuator removed to the bench follow steps: 1-4A, 5-9.

To change a diaphragm of a Reverse Acting (RA, NC, ATO) actuator assemble to the valve and under preload follow steps: 1-3, 4B, 5-10.

1. Shut off controlled medium supply (steam, water, or other liquid) and remove the control signal to the actuator.
2. Reduce preload on the springs. Follow procedures for Decreasing Preload on DA Actuators on pg. 7.

3. Remove the control signal to the actuator.
- 4A. (Fig 1) Remove top housing nuts and bolts or see above
- 4B. (Fig 1) Remove the three bolts attached to the short nuts, then equally release the bolts attached to the long nuts.

CAUTION: Springs under tension.

5. Remove upper housing (Fig 2).
 6. Remember the orientation of the springs. Remove springs, stem nut...(Fig. 3).
 7. ...silver washer, thrust plate, diaphragm, & black washer (Fig. 4).
 8. Replace with new diaphragm. Make sure the lip of the diaphragm is seated properly in the groove of the actuator housing.
 8. Reassemble in reverse order.
- NOTE: Assemble bolts with long nuts first.**
10. Adjust preload, refer to pg. 7.



Fig 1 - Remove Housing Bolts



Fig 2 - Remove Upper Housing, Remove Springs (4 Shown)



Fig 3 - Remove Stem Nut...



Fig 4 - Remove Thrust Plate and Old Diaphragm

PARTS LIST - DA ACTUATOR

ITEM	PART NUMBER	QUANTITY	PART DESCRIPTION
1	See Chart	1	Yoke (Cast Iron)
2	672-632A	1	Top Housing Machined
3	672-633A	1	Bottom Housing Machined
4	See Chart	1	Stem, D.A.
5	081-008	3	Nut, Housing
6	080-033	3	Bolt, Housing
7	672-646	See Chart	Spring, Small
8	672-645	See Chart	Spring, Large
9	672-626	1	Diaphragm
10	672-627	1	Thrust Plate, Steaming
11	672-618E	1	Bushing, Stem
12	084-015	2	"O" Ring
13	672-470A	1	Label Warning
14	043-009C	1	Cap Plug, 1/4"
15	082-005R	1	Washer, Stem
16	081-011	1	Nut, Stem
17	080-034	4	Bolt, Yoke
18	082-005	1	Washer, Stem
19	087-128	1	Vent Plug, 1/4" NPT
20	672-641	1	Bearing, Stem
22	672-620	1	Nameplate
23	See Chart	1	Locknut
24	900-326	3	Nut, Coupling 5/16-18x2
25	900-327	3	Bolt, 5/16-18 x 3LG

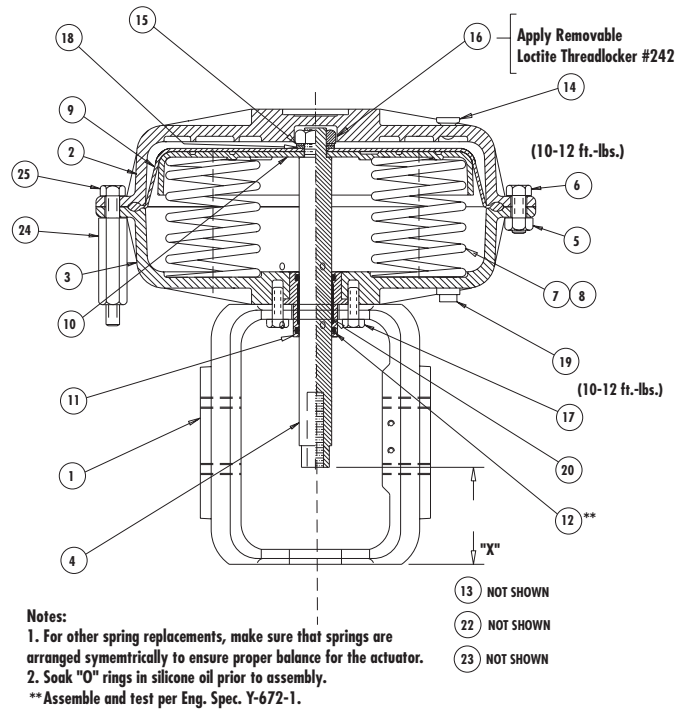

CURRENT ACTUATORS	STD. SPRINGS 672-642	STD. SPRINGS 672-615	SS. SPRINGS 672-645	SS. SPRINGS 672-646	STEM	YOKE	LOCK NUT
672022D	2	2	0	0	672-636	672-724	625-008
672033D	6	0	0	0	672-636	672-724	625-008
672044D	4	4	0	0	672-636	672-724	625-008
672601D	6	6	0	0	672-636	672-724	625-008
672602D	0	3	0	0	672-636	672-724	625-008
672603D	3	0	0	0	672-636	672-724	625-008
672604D	4	0	0	0	672-636	672-724	625-008
672605D	0	4	0	0	672-636	672-724	625-008
672606D	6	0	0	0	672-636	672-724	625-008
672607D	0	6	0	0	672-636	672-724	625-008
672651D	6	6	0	0	672-614	672-725	625-008
672653D	3	0	0	0	672-614	672-725	625-008
672654D	4	0	0	0	672-614	672-725	625-008
672655D	0	4	0	0	672-614	672-725	625-008
672656D	6	0	0	0	672-614	672-725	625-008
672657D	0	6	0	0	672-614	672-725	625-008
672666D	0	4	0	0	672-636B	672-725	625-008
672670D	0	6	0	0	672-636B	672-725	625-008
672671D	0	6	0	0	672-614B	672-725	625-008
672672D	0	4	0	0	672-614B	672-725	625-008
672726D	0	6	0	0	672-634	672-725	625-008
672727D	0	4	0	0	672-634	672-725	625-008
672728D	0	6	0	0	672-634	672-725	625-008
672-460D	0	0	0	3	672-636	672-724	625-008
672-474D	0	0	0	4	672-636	672-724	625-008
672-647D	0	0	0	6	672-636	672-724	625-008
672-474D	0	0	0	4	672-636	672-724	625-008
672-457D	0	0	0	6	672-636	672-724	625-008
672-461D	0	0	0	4	672-636	672-724	625-008
672-462D	0	0	0	6	672-636	672-724	625-008
672-463D	0	0	0	6	672-636	672-724	625-008
672-464D	0	0	0	6	672-636	672-724	625-008
672-648D	0	0	6	6	672-636	672-724	625-008
672-647D	0	0	6	0	672-636	672-724	625-008
672-474D	0	0	4	0	672-636	672-724	625-008
672-467D	0	0	4	4	672-636	672-724	625-008
672-465D	0	0	6	0	672-614B	672-725	625-008
672-466D	0	0	6	0	672-618E	672-725	625-008
672-469D	0	0	6	0	672-634	672-725	625-008
672-468D	0	0	6	0	672-634	672-725	625-008

PARTS LIST - RA ACTUATOR

ITEM	PART NUMBER	QUANTITY	PART DESCRIPTION
1	See Chart	1	Yoke (Cast Iron)
2	672-632A	1	Top Housing Machined
3	672-633A	1	Bottom Housing Machined
4	See Chart	1	Stem, D.A.
5	081-009	3	Nut, Housing
6	080-033	3	Bolt, Housing
7	672-645	See Chart	Spring, Large
8	672-646	See Chart	Spring, Small
9	672-626	1	Diaphragm
10	672-627	1	Thrust Plate, Steaming
11	672-618E	1	Bushing, Stem
12	084-015	2	"O" Ring
13	672-471	1	Label Warning
14	043-009C	1	Cap Plug, 1/4"
15	082-005R	1	Washer, Stem
16	081-011	1	Nut, Stem
17	080-034	4	Bolt, Yoke
18	082-005	1	Washer, Stem
19	087-128	1	Vent Plug, 1/4" NPT
20	672-641	1	Bearing, Stem
22	672-620	1	Nameplate
23	See Chart	1	Locknut
24	900-326	3	Nut, Coupling 5/16-18x2
25	900-327	3	Bolt, 5/16-18 x 3LG

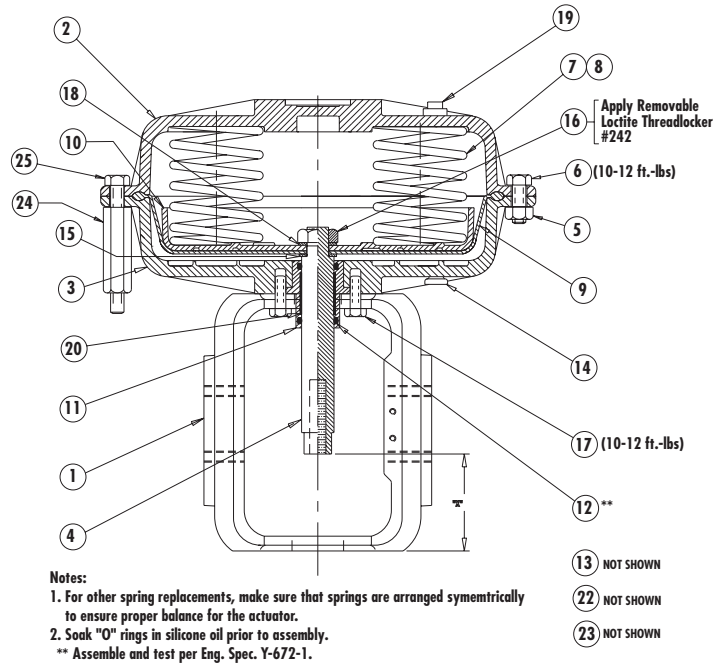

CURRENT ACTUATORS	STD. SPRINGS 672-642	STD. SPRINGS 672-615	SS. SPRINGS 672-645	SS. SPRINGS 672-646	STEM	YOKE	LOCK NUT
672024R	2	4	0	0	672-636A	672-724	628-008
672033R	3	3	0	0	672-636A	672-724	628-008
672044R	4	4	0	0	672-636A	672-724	628-008
672601R	6	6	0	0	672-636A	672-724	628-008
672602R	0	3	0	0	672-636A	672-724	628-008
672603R	3	0	0	0	672-636A	672-724	628-008
672604R	4	0	0	0	672-636A	672-724	628-008
672605R	0	4	0	0	672-636A	672-724	628-008
672606R	6	0	0	0	672-636A	672-724	628-008
672607R	0	6	0	0	672-636A	672-724	628-008
672645R	?		0	0	672-636A	672-724	628-008
672651R	6	6	0	0	672-614A	672-725	628-008
672653R	3	0	0	0	672-614A	672-725	628-008
672654R	4	0	0	0	672-614A	672-725	628-008
672655R	0	4	0	0	672-614A	672-725	628-008
672656R	6	0	0	0	672-614A	672-725	628-008
672657R	0	6	0	0	672-614A	672-725	628-008
672666R	0	4	0	0	672-636D	672-725	628-008
672668R	0	4	0	0	672-634B	672-724	628-008
672669R	0	6	0	0	672-634B	672-724	628-008
672670R	0	6	0	0	672-636C	672-725	628-008
672671R	0	6	0	0	672-634C	672-725	628-008
672672R	0	4	0	0	672-634C	672-725	628-008
672726R	0	6	0	0	672-634A	672-725	628-008
672727R	0	4	0	0	672-634A	672-725	628-008
672728R	0	6	0	0	672-634A	672-725	628-008
672-648R	0	0	0	3	672-636A	672-724	628-008
672-460R	0	0	0	4	672-636A	672-724	628-008
672-474R	0	0	0	6	672-636A	672-724	628-008
672-647R	0	0	0	4	672-636A	672-724	628-008
672-475R	0	0	0	6	672-636A	672-724	628-008

CURRENT ACTUATORS	SPRINGS				STEM	YOKE	LOCK NUT
	STD 672-642	STD 672-615	SS 672-646	SS 672-645			
672-457R	0	0	0	4	672-634A	672-725	628-008
672-461R	0	0	0	6	672-634A	672-725	628-008
672-462R	0	0	0	6	672-634A	672-725	628-008
672-463R	0	0	0	6	672-634A	672-725	628-008
672-464R	0	0	3	6	672-636A	672-725	628-008
672-645R	0	0	0	6	672-636A	672-724	628-008
672-458R	0	0	6	6	672-634A	672-725	628-008
672-644R	0	0	6	6	672-634A	672-725	628-008

SPRING RANGE MATRIX

The spring range matrix provides the theoretical spring ranges from a given spring arrangement and valve stem travel.

You are encouraged to discuss your application with one of the Powers application engineers.

In general, positioners are required to sequence valves. In some circumstances it may be possible to sequence valves by changing spring ranges and adjusting start points (preload adjustment). Again, please consult with one of our application engineers for assistance.

SPRING OPERATING SPAN (psi)

SPRINGS II		Total Spring Rate (lbs.)	Actuator Area = 46" Valve Stroke (inches)											
672-645	672-646		0	0.125	0.1875	0.25	0.3125	0.375	0.5626	0.625	0.75	1	1.25	1.5
Number of Springs														
0	0	0	0.0000	0.0000	0.0000	0.0000	0.0000	0.0000	0.0000	0.0000	0.0000	0.0000	0.0000	0.0000
2	0	164	0.4457	0.6685	0.8913	1.1141	1.3370	2.0058	2.2283	2.6739	3.5652	4.4565	5.3478	
3	0	246	0.6685	1.0027	1.3370	1.6712	2.0054	3.0087	3.3424	4.0109	5.3478	6.6848	8.0217	
4	0	328	0.8913	1.3370	1.7826	2.2283	2.6739	4.0116	4.4565	5.3478	7.1304	8.9130	10.6957	
6	0	492	1.3370	2.0054	2.6739	3.3424	4.0109	6.0174	6.6848	8.0217	10.6957	13.3696	16.0435	
0	2	104	0.2826	0.4239	0.5652	0.7065	0.8478	1.2720	1.4130	1.6957	2.2609	2.8261	3.3913	
2	2	268	0.7283	1.0924	1.4565	1.8207	2.1848	3.2778	3.6413	4.3696	5.8261	7.2826	8.7391	
3	2	350	0.9511	1.4266	1.9022	2.3777	2.8533	4.2807	4.7554	5.7065	7.6087	9.5109	11.4130	
4	2	432	1.1739	1.7609	2.3478	2.9348	3.5217	5.2835	5.8696	7.0435	9.3913	11.7391	14.0870	
6	2	596	1.6196	2.4293	3.2391	4.0489	4.8587	7.2893	8.0978	9.7174	12.9565	16.1957	19.4348	
0	3	156	0.4239	0.6359	0.8478	1.0598	1.2717	1.9079	2.1196	2.5435	3.3913	4.2391	5.0870	
2	3	320	0.8696	1.3043	1.7391	2.1739	2.6087	3.9137	4.3478	5.2174	6.9565	8.6957	10.4348	
3	3	402	1.0924	1.6386	2.1848	2.7310	3.2772	4.9166	5.4620	6.5543	8.7391	10.9239	13.1087	
4	3	484	1.3152	1.9728	2.6304	3.2880	3.9457	5.9195	6.5761	7.8913	10.5217	13.1522	15.7826	
6	3	648	1.7609	2.6413	3.5217	4.4022	5.2826	7.9253	8.8043	10.5652	14.0870	17.6087	21.1304	
0	4	208	0.5652	0.8478	1.1304	1.4130	1.6957	2.5439	2.8261	3.3913	4.5217	5.6522	6.7826	
2	4	372	1.0109	1.5163	2.0217	2.5272	3.0326	4.5497	5.0543	6.0652	8.0870	10.1087	12.1304	
3	4	454	1.2337	1.8505	2.4674	3.0842	3.7011	5.5526	6.1685	7.4022	9.8696	12.3370	14.8043	
4	4	536	1.4565	2.1848	2.9130	3.6413	4.3696	6.5555	7.2826	8.7391	11.6522	14.5652	17.4783	
6	4	700	1.9022	2.8533	3.8043	4.7554	5.7065	8.5613	9.5109	11.4130	15.2174	19.0217	22.8261	
0	6	312	0.8478	1.2717	1.6957	2.1196	2.5435	3.8159	4.2391	5.0870	6.7826	8.4783	10.1739	
2	6	476	1.2935	1.9402	2.5870	3.2337	3.8804	5.8217	6.4674	7.7609	10.3478	12.9348	15.5217	
3	6	558	1.5163	2.2745	3.0326	3.7908	4.5489	6.8246	7.5815	9.0978	12.1304	15.1630	18.1957	
4	6	640	1.7391	2.6087	3.4783	4.3478	5.2174	7.8275	8.6957	10.4348	13.9130	17.3913	20.8696	
6	6	804	2.1848	3.2772	4.3696	5.4620	6.5543	9.8333	10.9239	13.1087	17.4783	21.8478	26.2174	

672-615 STANDARD	TOTAL SPRING RATE (lbs.)	VALVE STROKES (inches)				
Number of Springs		0.125	0.1875	0.25	0.3125	0.375
0	0	0.0000	0.0000	0.0000	0.0000	0.0000
1	245	0.6658	0.9986	1.3315	1.6644	1.9973
2	490	1.3315	1.9973	2.6630	3.3288	3.9946
3	735	1.9973	2.9959	3.9946	4.9932	5.9918
4	980	2.6630	3.9946	5.3261	6.6576	7.9891
5	1225	3.3288	4.9932	6.6576	8.3220	9.9864
6	1470	3.9946	5.9918	7.9891	9.9864	11.9837

Part No.	Dia.	Spring Rate
672-642	1.406"	82
672-615	2.175"	245
672-645	2.9"	82
672-646	1.459"	52

MODIFICATION DATA TABLES

These tables provide actuator design information with regard to the specific valve type and size. Use this information to determine which springs to use, the number of springs required, and spring kit part numbers.

These are the correct preload adjustments when mounting an actuator on a valve or changing stems:

5 psi for NO assemblies

7-10 psi for NC assemblies

Use these pressure and the "Valve Travel" data to properly adjust the stem length of your actuator/valve assembly.

Example:

Change a

Single Seat Stainless Trim reduced port 1/2A size valve, with a normally open actuator assembly (593 VE A50 NO)

to a

Single Seat Stainless Trim 1/2" size valve with a Normally Closed assembly (593 SS 050 NC).

1. Look up the references to the type of valve you want. In this case, refer to the SS Valve Type, Table 4.
2. You need a new stem, part #672636A. You also need four #672-615 springs.
3. Now install the new parts. Refer to the section on Changing Actuator Action from DA to RA.
4. Also consult the section Changing Springs on a Reverse Acting Actuator. See Figure 3A & B for Typical 4 Spring Installation for symmetrical spring orientation.

TABLE 1

VALVE TYPE	ASSEMBLY ACTION	VALVE SIZE	46 ACTUATOR PART #	46 SPRING PART#	4C ACTUATOR PART #	4C SPRING PART#	SPRING QUANTITY	STEM PART #	VALVE TRAVEL (in)
SI	NO	2-1/2	672-672D	672-642	672-466D	672-646	6	672-636B	5/8
	NO	3	672-672D	672-642	672-466D	672-646	6	672-636B	3/4
	NO	4	672-672D	672-642	672-466D	672-646	4	672-636B	1
	NC	2-1/2	672-024R	672-642	672-465R	672-646	6	672-636C	5/8
	NC	3	672-024R	672-642	672-465R	672-646	6	672-636C	3/4
	NC	4	672-024R	672-642	672-465R	672-646	6	672-636D	1

*4X Actuators add 6 Springs #672-645.

TABLE 2

VALVE TYPE	ASSEMBLY ACTION	VALVE SIZE	46 ACTUATOR PART #	46 SPRING PART#	4C ACTUATOR PART #	4C SPRING PART#	SPRING QUANTITY	STEM PART #	VALVE TRAVEL (in)
VE	NO	1/2A	672-022D	672-642	672-648D	672-646	6	672-636	1/4
	NO	1/2B	672-022D	672-642	672-648D	672-646	6	672-636	1/4
	NO	1/2C	672-022D	672-642	672-648D	672-646	6	672-636	1/4
	NO	1/2D	672-022D	672-642	672-648D	672-646	6	672-636	1/4
	NC	1/2A	672-024R	672-642	672-648R	672-646	6	672-636A	1/4
	NC	1/2B	672-024R	672-642	672-648R	672-646	6	672-636A	1/4
	NC	1/2C	672-024R	672-642	672-648R	672-646	6	672-636A	1/4
	NC	1/2D	672-024R	672-642	672-648R	672-646	6	672-636A	1/4

*4X Actuators add 6 Springs #672-645.

TABLE 3

VALVE TYPE	ASSEMBLY ACTION	VALVE SIZE	46 ACTUATOR PART #	46 SPRING PART#	4C ACTUATOR PART #	4C SPRING PART#	SPRING QUANTITY	STEM PART #	VALVE TRAVEL (in)
WM	N/A	1/2	672-022D	672-615	672-648D	672-646	6	672 636	1/8
	N/A	1/2	672-022D	672-642	672-648D	672-646	6	672 636	1/8
	N/A	3/4	672-022D	672-615	672-648D	672-646	6	672 636	3/16
	N/A	3/4	672-022D	672-642	672-648D	672-646	6	672 636	3/16
	N/A	1	672-022D	672-615	672-648D	672-646	6	672 636	1/4
	N/A	1-1/4	672-022D	672-615	672-648D	672-646	4	672 636	5/16
	N/A	1-1/2	672-022D	672-615	672-648D	672-646	4	672 636	5/16
	N/A	2	672-022D	672-615	672-647D	672-646	4	672 636	5/16
MI	N/A	2-1/2	672-671D	672-642	672-465D	672-646	6	672636B	5/8
	N/A	3	672-671D	672-642	672-465D	672-646	6	672636B	3/4
	N/A	4	672-671D	672-642	672-465D	672-646	6	672636B	1

*4X Actuators add 6 Springs #672-645.

TABLE 4

VALVE TYPE	ASSEMBLY ACTION	VALVE SIZE	46 ACTUATOR PART #	46 SPRING PART#	4C ACTUATOR PART #	4C SPRING PART#	SPRING QUANTITY	STEM PART #	VALVE TRAVEL (in)
SS	NO	1/2	672-607D	672-615	672-647D	672-646	6	672-636	3/8
	NO	3/4	672-607D	672-642	672-647D	672-646	6	672-636	3/4
	NO	1	672-607D	672-642	672-647D	672-646	6	672-636	3/4
SD	NO	1-1/4	672-607D	672-642	672-647D	672-646	6	672-636	1
	NO	1-1/2	672-607D	672-642	672-647D	672-646	6	672-636	1
	NO	2	672-607D	672-642	672-647D	672-646	6	672-636	1
SP	NC	1/2	672-607R	672-642	672-647R	672-646	6	672-636A	3/8
	NC	3/4	672607R	672-642	672-647R	672-646	6	672-636A	3/4
	NC	1	672607R	672-642	672-647R	672-646	6	672-636A	3/4
	NC	1-1/4	672605R	672-642	672-647R	672-646	6	672-636A	1
	NC	1-1/2	672605R	672-642	672-647R	672-646	6	672-636A	1
NC	2	672605R	672-642	672-647R	672-646	6	672-636A	1	

***4X Actuators add 6 Springs #672-645.**

TABLE 5

VALVE TYPE	ASSEMBLY ACTION	VALVE SIZE	46 ACTUATOR PART #	46 SPRING PART#	4C ACTUATOR PART #	4C SPRING PART#	SPRING QUANTITY	STEM PART #	VALVE TRAVEL (in)
DB	NO	1	672-022D	672-615	672-648D	672-646	6	672-636	3/16
	NO	1	672-022D	672-642	672-648D	672-646	6	672-636	3/16
	NO	1-1/4	672-022D	672-615	672-648D	672-646	6	672-636	1/4
	NO	1-1/2	672-022D	672-615	672-648D	672-646	6	672-636	1/4
	NO	2	672-022D	672-615	672-648D	672-646	6	672-636	3/8
	NC	1	672-024R	672-615	672-648R	672-646	6	672-636A	3/16
	NC	1	672-024R	672-642	672-648R	672-646	6	672-636A	3/16
	NC	1-1/4	672-024R	672-615	672-648R	672-646	6	672-636A	1/4
	NC	1-1/2	672-024R	672-615	672-648R	672-646	6	672-636A	1/4
	NC	2	672-024R	672-615	672-466D	672-646	6	672-636A	3/8
DI	NO	2-1/2	672-672D	672-615	672-466D	672-646	6	672-636A	3/8
	NO	3	672-672D	672-615	672-466D	672-646	6	672-636A	9/16
	NO	4	672-672D	672-615	672-466D	672-646	6	672-636A	9/16
	NO	5	672-672D	672-642	672-466D	672-646	6	672-636A	3/4
	NO	6	672-672D	672-642	672-466D	672-646	6	672-634	1
	NC	2-1/2	672-671R	672-615	672-465R	672-646	6	672-636A	3/8
	NC	3	672-671R	672-615	672-465R	672-646	6	672-636A	9/16
	NC	4	672-671R	672-615	672-465R	672-646	6	672-636A	9/16
	NC	5	672-671R	672-642	672-465R	672-646	6	672-636A	3/4
	NC	6	672-671R	672-642	672-465R	672-646	6	672-636A	1

***4X Actuators add 6 Springs #672-645.**

TABLE 6

VALVE TYPE	ASSEMBLY ACTION	VALVE SIZE	46 ACTUATOR PART #	46 SPRING PART#	4C ACTUATOR PART #	4C SPRING PART#	SPRING QUANTITY	VALVE TRAVEL (in)
SB	NO	1/2	672-727D	672-642	672-468D	672-646	4	9/16
	NO	3/4	672-727D	672-642	672-468D	672-646	4	9/16
	NO	1	672-727D	672-642	672-468D	672-646	4	3/4
	NO	1 1/4	672-727D	672-642	672-468D	672-646	4	3/4
	NO	1 1/2	672-727D	672-642	672-468D	672-646	4	3/4
	NO	2	672-727D	672-642	672-468D	672-646	4	3/4
	NC	1/2	672-726R	672-642	672-469R	672-646	6	9/16
	NC	3/4	672-726R	672-642	672-469R	672-646	6	9/16
	NC	1	672-726R	672-642	672-469R	672-646	6	3/4
	NC	1 1/4	672-726R	672-642	672-469R	672-646	6	3/4
	NC	1 1/2	672-726R	672-642	672-469R	672-646	6	3/4
	NC	2	672-726R	672-642	672-469R	672-646	6	3/4

***4X Actuators add 6 Springs #672-645.**

CALIFORNIA PROPOSITION 65 WARNING

WARNING: This product contains chemicals known to the State of California to cause cancer and birth defects or other reproductive harm. (Installer: California law requires that this warning be given to the consumer.)

For more information: www.wattsind.com/prop65

<p>POWERS</p> <p>A WATTS INDUSTRIES CO. www.powerscontrols.com</p>	<p>USA office: Phone: 800.669.5430 • Fax: 847.824.0627 Canadian office: Phone: 888.208.8927 • Fax: 888.882.1979</p> <p>© 2002 Powers, a Watts Industries Co.</p>
--	---