

For Water Heater Applications

Job Name _____

Contractor _____

Job Location _____

Approval _____

Engineer _____

Contractor's P.O. No. _____

Approval _____

Representative _____

Series SL100XL, L100XL, LL100XL and LLL100XL Extended Shank

Size ¾" (20mm)

CSA Rated. Standard Models are self-closing T&P Relief Valves for Water Heaters up to 105,000 BTU/Hr.

Watts Series SL100XL, L100XL, LL100XL and LLL100XL have extended inlet shanks for use with the new generation of water heaters containing extra thick insulation. These valves eliminate the use of an extension nipple required with standard shank length models.

The combined 2-in-1 Temperature & Pressure relief valve provides the least expensive and proven means for protection against both excessive temperature and pressure emergency conditions.

Watts Self-closing combination T&P relief valves are design certified, rated and listed by CSA to the requirements of ANSI Z21.22; and by the National Board to the requirements of ASME Section IV.

They provide fully automatic temperature and pressure relief protection for hot water storage tanks and heaters up to 105,000 BTU/Hr.

The temperature sensing element must be immersed in the water within the top 6" (152mm) of the tank. Male inlet and female outlet. Temperature relief 210°F (99°C). Standard setting 75, 100, 125, 150psi (5.3, 7.0, 8.8, 10.6 bar).

Features

- Model SL100XL Extended inlet model for installations with thick insulation. Suitable for water heaters with up to 1¾" (44.5mm) of insulation
- Model L100XL Extended inlet model for installations with thick insulation. Suitable for water heaters with up to 2" (50.8mm) of insulation
- Model LL100XL Extra extended inlet model. Suitable for water heaters with up to 2½" (63.5mm) of insulation
- Model LLL100XL Extra extended inlet model. Suitable for water heaters with up to 3" (76mm) of insulation
- Thermostats with special protective coating
- All brass body
- Stainless steel spring
- Thermostat is accurate and proven. Exclusively designed and manufactured by Watts



LLL100XL

LL100XL

L100XL

SL100XL

Specifications

Temperature & Pressure Relief Valves

Each hot water storage heater shall be equipped with a CSA and ASME rated automatic temperature and pressure relief valve to protect the heater from excessive pressure and excessive temperature. The device shall be design certified, rated and listed by CSA to the requirements of ANSI Z21.22; and by the National Board to the requirements of ASME Section IV. The BTU discharge capacity of the device shall be in excess of the BTU input rating of the heater. Watts Series SL100XL, L100XL, LL100XL or LLL100XL.

⚠ WARNING

This device is designed for emergency safety relief and shall not be used as an operating control.

NOTICE

The information contained herein is not intended to replace the full product installation and safety information available or the experience of a trained product installer. You are required to thoroughly read all installation instructions and product safety information before beginning the installation of this product.

NOTICE

Inquire with governing authorities for local installation requirements

Watts product specifications in U.S. customary units and metric are approximate and are provided for reference only. For precise measurements, please contact Watts Technical Service. Watts reserves the right to change or modify product design, construction, specifications, or materials without prior notice and without incurring any obligation to make such changes and modifications on Watts products previously or subsequently sold.

Series SL100XL, L100XL, LL100XL and LLL100XL

- Model SL100XL** Suitable for water heaters with up to 1¾" (44mm) of insulation
- Model L100XL** Suitable for water heaters with up to 2" (50.8mm) of insulation
- Model LL100XL** Suitable for water heaters with up to 2½" (63.5mm) of insulation
- Model LLL100XL** Suitable for water heaters with up to 3" (76mm) of insulation

Dimensions – Weights

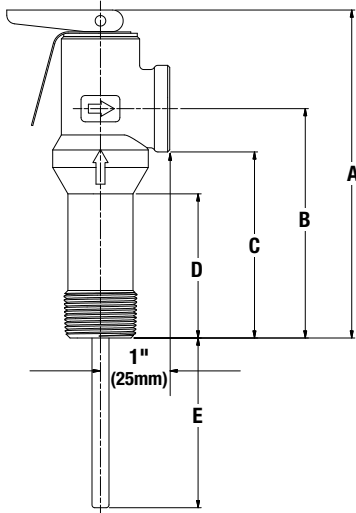

Direct Side Tapping

Vertical discharge line must be installed with its direction downward.

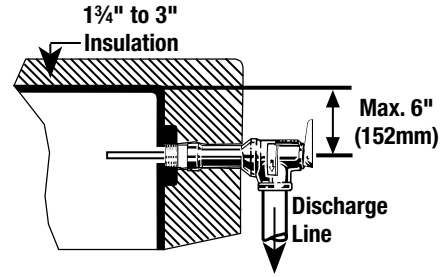

For Heaters with Direct Top Tapping

Use standard or extra length extension thermostat.

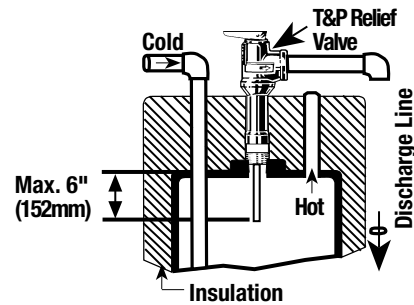

MODEL	SIZE		WIDTH		DIMENSIONS								WEIGHT		C.S.A TEMP STEAM RATING		
	in.	mm	in.	mm	A		B		C		D		E			lbs.	kgs
SL100XL	¾	20	1⅞	48	3⅛	100	2½	63	1⅞	47	1¼	31	3⅞	84	.58	.26	105,000 BTU/hr
L100XL	¾	20	1⅞	48	4⅞	109	2⅜	71	2⅞	56	1⅞	40	2⅞	75	.61	.28	105,000 BTU/hr
LL100XL	¾	20	1⅞	48	4⅞	122	3⅞	84	2⅞	68	2⅞	53	2⅞	62	.65	.29	105,000 BTU/hr
LLL100XL	¾	20	1⅞	48	5⅞	132	3¾	94	3⅞	79	2½	63	2⅞	52	.68	.31	105,000 BTU/hr

⚠ WARNING

REINSPECTION OF T&P RELIEF VALVE: Temperature and Pressure Relief Valves should be reinspected AT LEAST ONCE EVERY THREE YEARS by a licensed plumbing contractor or authorized inspection agency, to insure that the product has not been affected by corrosive water conditions and to insure that the valve and discharge line have not been altered or tampered with illegally. Certain naturally occurring conditions may corrode the valve or its components over time, rendering the valve inoperative. Such conditions are not detectable unless the valve and its components are physically removed and inspected. Do not attempt to conduct this inspection on your own. Contact your plumbing contractor for a reinspection to assure continuing safety. **FAILURE TO REINSPECT THIS VALVE AS DIRECTED COULD RESULT IN UNSAFE TEMPERATURE OR PRESSURE BUILD-UP WHICH CAN RESULT IN SERIOUS INJURY OR DEATH AND/OR SEVERE PROPERTY DAMAGE.**

IMPORTANT: A relief valve functions in an emergency by discharging water. Therefore, it is essential that a discharge line be piped from the valve in order to carry the overflow to a safe place of disposal. The discharge line must be the same size as the valve outlet and must pitch downward from the valve and terminate at least 6"(152mm) above the floor drain where any discharge will be clearly visible. For 100DT discharge line consult your Watts agent.

