

- NOTES:
- ALL DIMENSIONS SHOWN IN TABLE ARE IN INCHES, UNLESS OTHERWISE NOTED & ARE ± 1 INCH (25MM).
 - ALL ITEMS SHOWN IN PHANTOM LINE ARE TO BE PROVIDED BY OTHERS.
 - ALL DIMENSIONS ARE SUBJECT TO CHANGE WITHOUT ANY NOTICE.
 - INSTALL UNIONS FITTINGS ON INLET, OUTLET & DRAIN PLUMBING CONNECTIONS.
 - PROVIDE A 2 FEET MINIMUM CLEARANCE ABOVE MINERAL TANK FOR FILLING MEDIA.
 - A GFCI EQUIPT ELECTRICAL OUTLET SHOULD BE PROVIDED WITHIN 5 FEET OF EQUIPMENT LOCATION.
 - USE DIELECTRIC UNIONS ON PLUMBING CONNECTIONS OF CONTROL VALVE WHEN DISSIMILAR METALS ARE PRESENT.
 - PROVIDED SYSTEM SHALL NOT BE SUBJECT TO ANY VACUUM. IF RISK OF VACUUM IS PRESENT, INSTALL SIPHON BREAK ON DRAIN LINE & INSTALL VACUUM RELIEF VALVE WATTS ORDERING CODE # 0556031 ON INLET LINE.
 - BRINE TANK DIMENSIONS SHOWN ON TABLE ARE FACTORY SELECTED FOR USE WITH THE SPECIFIED SYSTEM SIZE.
 - DO NOT INSTALL DRAIN LINE DIRECTLY TO A DRAIN. FOR PROPER DRAIN CONNECTION FOLLOW ALL NATIONAL, STATE AND LOCAL CODES. DO NOT CONSTRUCT DRAIN LINE TO ELEVATIONS THAT EXCEED 4 FEET ABOVE THE CONTROL VALVE'S DRAIN PORT.
 - THE FULL WEIGHT OF THE PIPING AND VALVES MUST BE SUPPORTED BY PIPE HANGERS OR OTHER MEANS.
 - INLET AND OUTLET HEADERS NEED TO BE SIZED ACCORDING TO FLOW RATE REQUIREMENTS BY OTHERS.
 - POWER REQUIREMENTS: 115V/60HZ 2.7 AMPS PER CONTROL VALVE UNLESS OTHERWISE SPECIFIED.
 - BRINE TANK MUST BE LOCATED WITHIN 10 FEET OF SYSTEM CONTROL VALVE AND ON A COMMON FLOOR ELEVATION WITH MINERAL TANK TO ENSURE PROPER BRINE DRAW OPERATION.
 - USE FACTORY SUPPLIED BRINE TUBING. DO NOT USE SMALLER DIAMETER TUBING THAN WHAT IS SUPPLIED.
 - LIMIT INLET PRESSURE TO NOT EXCEED MAXIMUM PUBLISHED OPERATING PRESSURE.

SERIES PWS20 SIMPLEX DIMENSION (INCHES) & SPECIFICATIONS

MODEL NO.	ORDERING CODES (EDP NO.)	MINERAL TANK SIZE	INLET	OUTLET	OVERALL HEIGHT (SEE NOTE 5)	OVERALL DEPTH	OVERALL WIDTH	MINIMUM INLET PIPE DISTANCE	BRINE TANK (SEE NOTE 9)	CONTROL VALVE INLET/OUTLET PIPE SIZE (NPT)	DRAIN CONN. SIZE (NPT)	SERVICE FLOW GPM @ 15 PSI DROP	PEAK SERVICE FLOW GPM @ 25 PSI DROP	DRAIN FLOW RATE (GPM)	MIN/MAX OPERATING TEMP F°	MIN/MAX OPERATING PRESSURE (PSI)	ESTIMATED OPERATING WEIGHT (LBS)	ESTIMATED SHIPPING WEIGHT (LBS)
PWS20131D11	7100031	14 X 65	67.38	67.38	77.13	16	21.13	3.5	18 X 40	2.0	1.0	25	40	5.0	34/110	25/125	951	350
PWS20131E11	7100032	16 X 65	67.75	67.75	77.88	17	22.25	5.5	18 X 40	2.0	1.0	35	55	7.0	34/110	25/125	1119	350
PWS20131F11	7100033	18 X 65	68.5	68.5	78.94	18.13	23.25	7.5	24 X 41	2.0	1.0	57	65	10.0	34/110	25/125	1481	400
PWS20131G11	7100034	21 X 62	70.5	70.5	80.94	21.13	24.69	10.5	24 X 50	2.0	1.0	60	77	12.0	34/110	25/125	2044	600
PWS20131H11	7100035	24 X 72	76.75	76.75	87.13	24.13	26.25	13.5	30 X 50	2.0	1.0	74	97	15.0	34/110	25/125	2996	710
PWS20131I11	7100036	30 X 72	80.25	80.25	93.13	30.13	30.13	16.5	39 X 48	2.0	1.0	80	100	25.0	34/110	25/125	4717	1160
PWS20131J11	7100037	36 X 72	86	86	97.44	36.13	36.13	22.5	39 X 60	2.0	1.5	84	105	35.0	34/110	25/125	6206	1560

WATTS 815 CHESTNUT ST. NORTH ANDOVER, MA 01845

THIS DRAWING IS UNLESS SPECIFIED

FRAC TIONAL ANGULAR 1/16" #11 DECIMAL 48mm 3/32" X 1/8" 1.588 1/8" 3/16" X 1/4" 2.362 3/8" COMMON BASE 1/4" 1/2" 3/8" TIR SURFACE FINISH UNFINISHED 1/2" X 1/2" RMS

DO NOT SCALE DRAWING

DWG BY: JR DATE: 1/28/2021 SCALE: NTS SUPERSEDES: SHEET: 1 OF 1

TITLE: GENERAL INSTALLATION, SERIES PWS20 SIMPLEX 2" WATER SOFTENERS

PART NO.: SEE TABLE

MATERIAL: N/A

OTHER: ESTIMATED WEIGHT: SEE TABLE

EDP NO.: SEE TABLE

FILE TYPE: CAD

SIZE: D

REV: 1

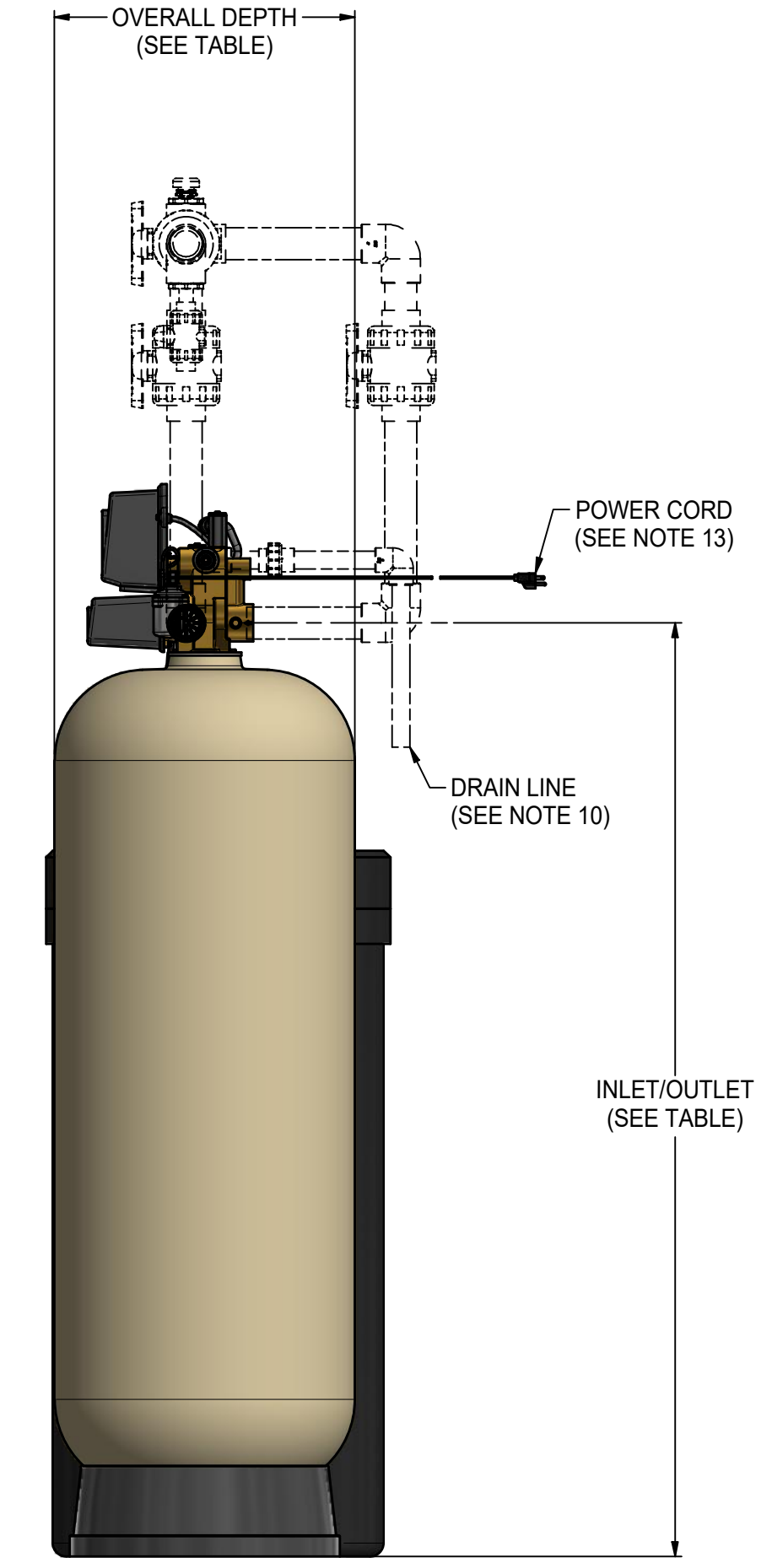
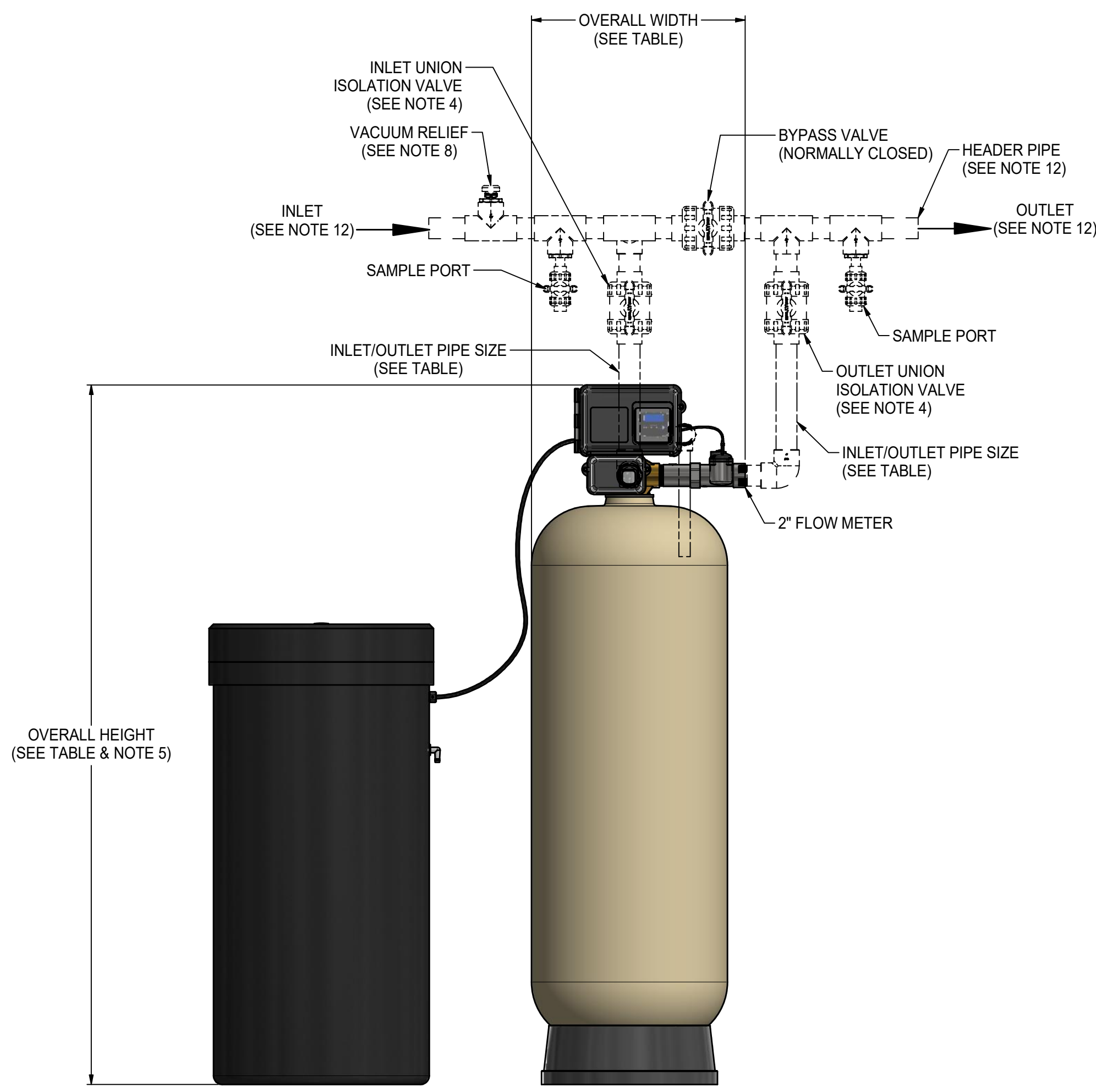
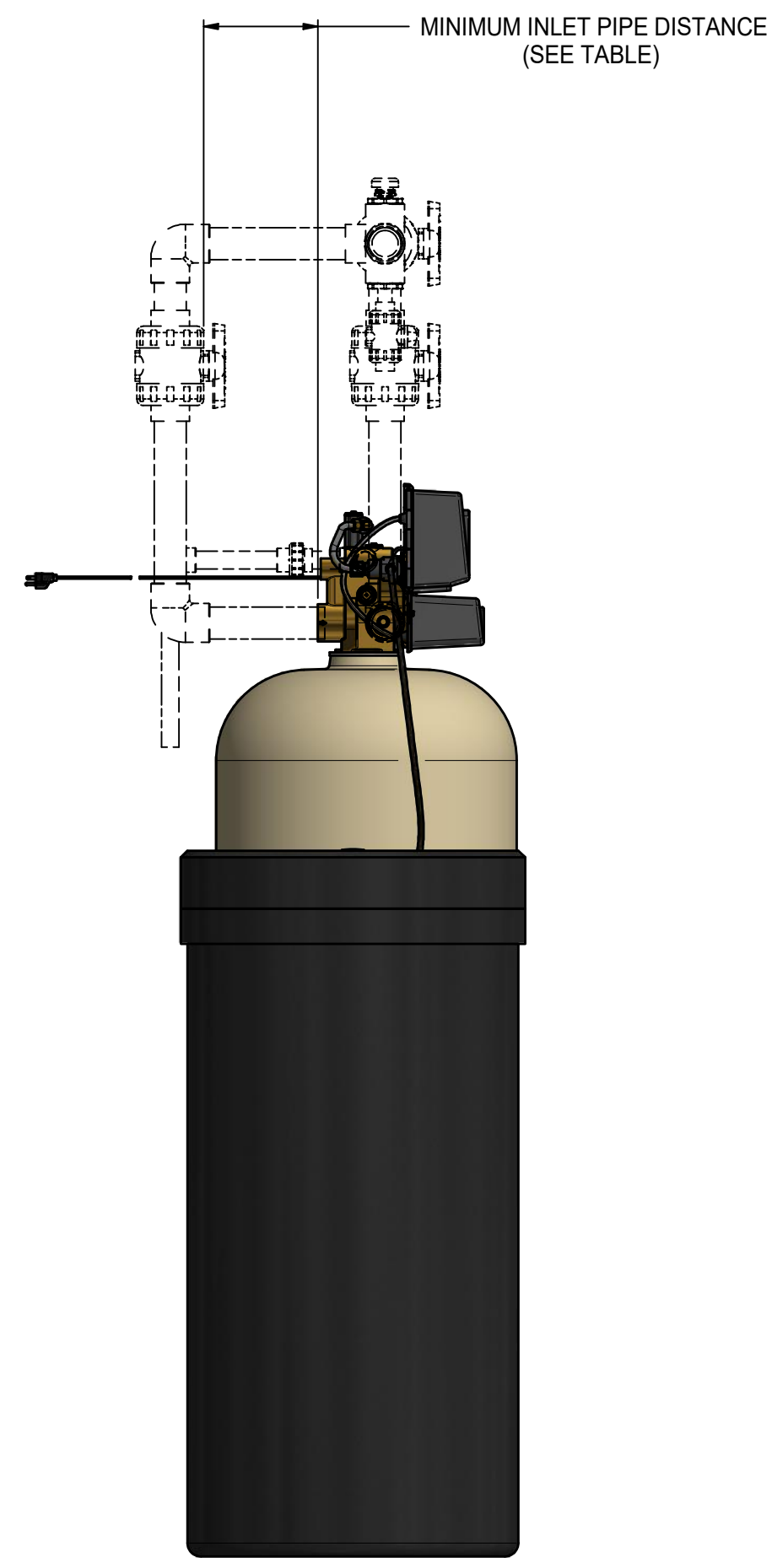
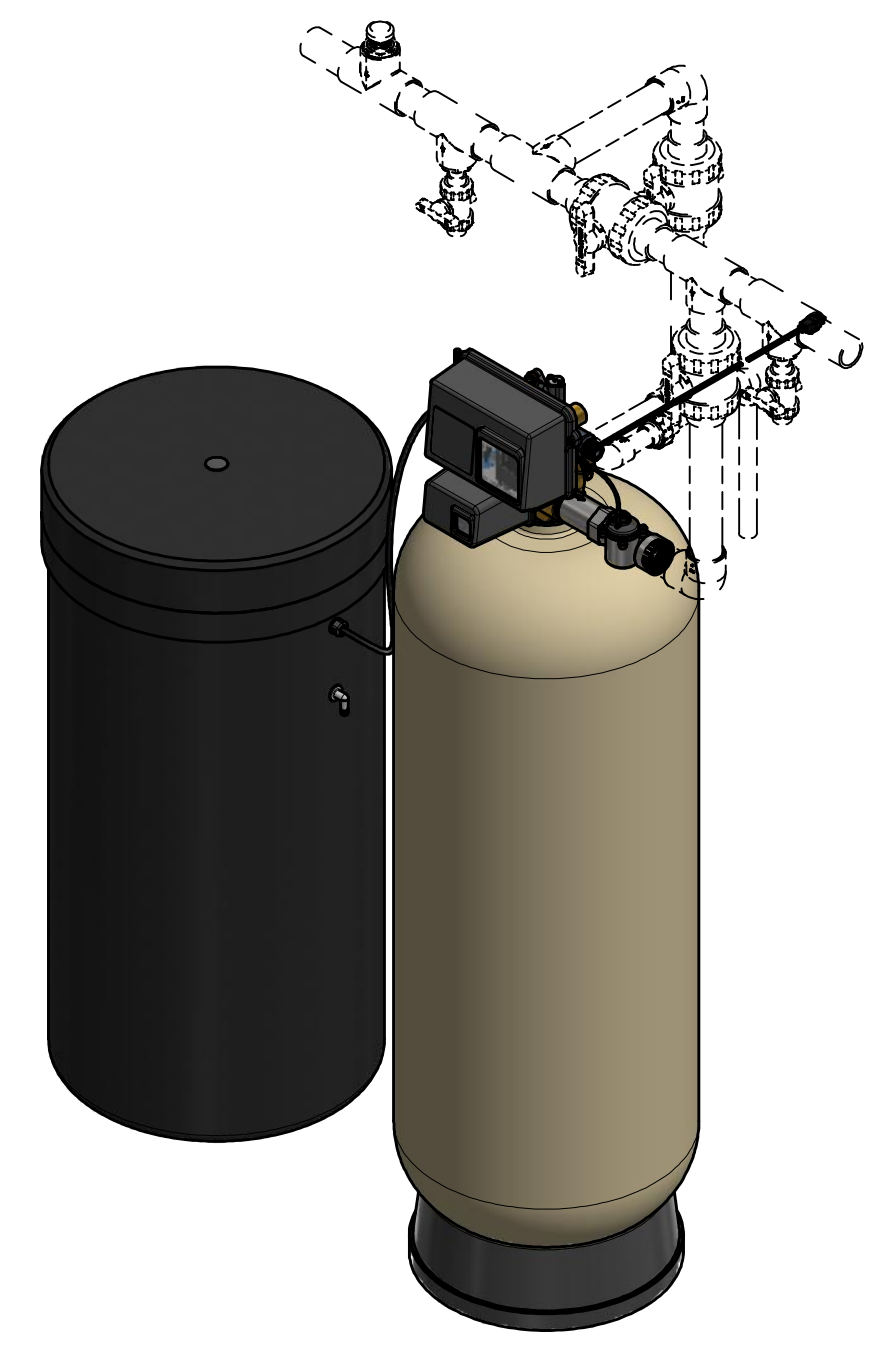
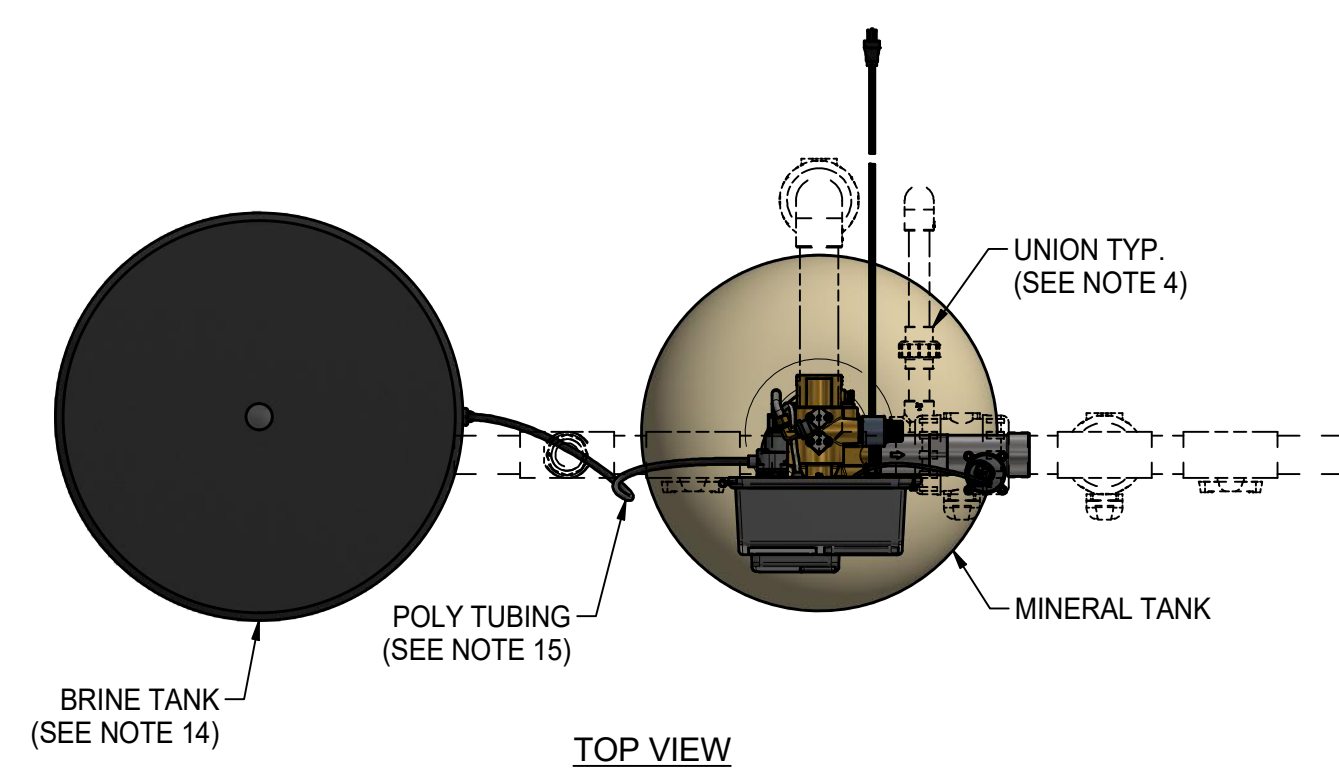

CLIENT PROJECT SIGN-OFF

JOB NAME: _____

JOB LOCATION: _____

CONTRACTOR: _____

CONTRACTOR APPROVAL: _____

CONTRACTOR APPROVAL DATE: _____

CONTRACTOR PO NO: _____

ENGINEER: _____

ENGINEER APPROVAL: _____

ENGINEER APPROVAL DATE: _____